

**NetTek® YBT250**  
**Field Transmitter & Interference Tester**  
**Quick Start User Manual**

[www.tektronix.com](http://www.tektronix.com)  
071-2409-00

**Tektronix**

Copyright © Tektronix. All rights reserved. Licensed software products are owned by Tektronix or its subsidiaries or suppliers, and are protected by national copyright laws and international treaty provisions.

Tektronix products are covered by U.S. and foreign patents, issued and pending. Information in this publication supersedes that in all previously published material. Specifications and price change privileges reserved.

TEKTRONIX and TEK are registered trademarks of Tektronix, Inc.

NetTek is a registered trademark of Tektronix, Inc.

## Contacting Tektronix

Tektronix, Inc.  
14200 SW Karl Braun Drive  
P.O. Box 500  
Beaverton, OR 97077  
USA

For product information, sales, service, and technical support:

- In North America, call 1-800-833-9200.
- Worldwide, visit [www.tektronix.com](http://www.tektronix.com) to find contacts in your area.

## Warranty 2

Tektronix warrants that this product will be free from defects in materials and workmanship for a period of one (1) year from the date of shipment. If any such product proves defective during this warranty period, Tektronix, at its option, either will repair the defective product without charge for parts and labor, or will provide a replacement in exchange for the defective product. Parts, modules and replacement products used by Tektronix for warranty work may be new or reconditioned to like new performance. All replaced parts, modules and products become the property of Tektronix.

In order to obtain service under this warranty, Customer must notify Tektronix of the defect before the expiration of the warranty period and make suitable arrangements for the performance of service. Customer shall be responsible for packaging and shipping the defective product to the service center designated by Tektronix, with shipping charges prepaid. Tektronix shall pay for the return of the product to Customer if the shipment is to a location within the country in which the Tektronix service center is located. Customer shall be responsible for paying all shipping charges, duties, taxes, and any other charges for products returned to any other locations.

This warranty shall not apply to any defect, failure or damage caused by improper use or improper or inadequate maintenance and care. Tektronix shall not be obligated to furnish service under this warranty a) to repair damage resulting from attempts by personnel other than Tektronix representatives to install, repair or service the product; b) to repair damage resulting from improper use or connection to incompatible equipment; c) to repair any damage or malfunction caused by the use of non-Tektronix supplies; or d) to service a product that has been modified or integrated with other products when the effect of such modification or integration increases the time or difficulty of servicing the product.

THIS WARRANTY IS GIVEN BY TEKTRONIX WITH RESPECT TO THE PRODUCT IN LIEU OF ANY OTHER WARRANTIES, EXPRESS OR IMPLIED. TEKTRONIX AND ITS VENDORS DISCLAIM ANY IMPLIED WARRANTIES OF MERCHANTABILITY OR FITNESS FOR A PARTICULAR PURPOSE. TEKTRONIX' RESPONSIBILITY TO REPAIR OR REPLACE DEFECTIVE PRODUCTS IS THE SOLE AND EXCLUSIVE REMEDY PROVIDED TO THE CUSTOMER FOR BREACH OF THIS WARRANTY. TEKTRONIX AND ITS VENDORS WILL NOT BE LIABLE FOR ANY INDIRECT, SPECIAL, INCIDENTAL, OR CONSEQUENTIAL DAMAGES IRRESPECTIVE OF WHETHER TEKTRONIX OR THE VENDOR HAS ADVANCE NOTICE OF THE POSSIBILITY OF SUCH DAMAGES.



# Table of Contents

General Safety Summary .....	iii
Environmental Considerations .....	vi
Preface.....	vii
Key Features .....	vii
Documentation .....	viii
Software Upgrades .....	ix
Conventions Used in This Manual.....	ix
Preventing Personal Injury from Lightning .....	x
Installation .....	1
YBT250 Standard Accessories .....	1
Operating Considerations .....	2
Connecting the AC Adapter .....	4
Charging the Batteries .....	5
Powering On and Off the Instrument, and Functional Verification .....	6
Touch Screen Concepts .....	7
Calibrate the Touch Screen.....	8
Starting the YBT250 Application.....	10
Setting Display Colors .....	11
Enabling Signal Standards .....	12

Getting Acquainted with Your Instrument .....	15
Instrument Elements .....	15
Power On/Standby and Status Panel .....	16
Input/Output Connectors (NetTek Y400 Platform) .....	17
NetTek YBT250 Module Signal Connectors.....	18
Microsoft WindowsCE Elements .....	18
The User Interface .....	19
The Command Bar.....	20
The Tuning Controls .....	21
The External Signal Status Buttons .....	22
The Measurement Mode Buttons.....	23
The Parameter Entry Controls.....	24
Getting Help.....	25
Operating Basics .....	27
Setting Up to Take a Measurement .....	27
Signal Measurements.....	32
Spectrum Measurements .....	34
Interference Measurements .....	45
Displaying Multiple Measurements .....	58
Specifications .....	61
Certifications and Compliances .....	88
Index .....	

# General Safety Summary

Review the following safety precautions to avoid injury and prevent damage to this product or any products connected to it.

To avoid potential hazards, use this product only as specified.

*Only qualified personnel should perform service procedures.*

While using this product, you may need to access other parts of a larger system. Read the safety sections of the other component manuals for warnings and cautions related to operating the system.

## To Avoid Fire or Personal Injury

**Use Proper Power Cord.** Use only the power cord specified for this product and certified for the country of use.

**Observe All Terminal Ratings.** To avoid fire or shock hazard, observe all ratings and markings on the product. Consult the product manual for further ratings information before making connections to the product.

The inputs are not rated for connection to mains or Category II, III, or IV circuits.

**Power Disconnect.** The power cord disconnects the product from the power source. Do not block the power cord; it must remain accessible to the user at all times.

**Do Not Operate Without Covers.** Do not operate this product with covers or panels removed.

**Do Not Operate With Suspected Failures.** If you suspect that there is damage to this product, have it inspected by qualified service personnel.

**Avoid Exposed Circuitry.** Do not touch exposed connections and components when power is present.

**Replace Batteries Properly.** Replace batteries only with the specified type and rating.

**Recharge Batteries Properly.** Recharge batteries for the recommended charge cycle only.

**Use Proper AC Adapter.** Use only the AC adapter specified for this product.

**Do Not Operate in an Explosive Atmosphere.**

## Terms in this Manual

These terms may appear in this manual:



---

**WARNING.** *Warning statements identify conditions or practices that could result in injury or loss of life.*

---



---

**CAUTION.** *Caution statements identify conditions or practices that could result in damage to this product or other property.*

---

## Symbols and Terms on the Product

These terms may appear on the product:

- DANGER indicates an injury hazard immediately accessible as you read the marking.
- WARNING indicates an injury hazard not immediately accessible as you read the marking.
- CAUTION indicates a hazard to property including the product.



The following symbol(s) may appear on the product:



Standby

## Environmental Considerations

This section provides information about the environmental impact of the product.

### Product End-of-Life Handling

Observe the following guidelines when recycling an instrument or component:

**Equipment Recycling.** Production of this equipment required the extraction and use of natural resources. The equipment may contain substances that could be harmful to the environment or human health if improperly handled at the product's end of life. In order to avoid release of such substances into the environment and to reduce the use of natural resources, we encourage you to recycle this product in an appropriate system that will ensure that most of the materials are reused or recycled appropriately.



This symbol indicates that this product complies with the European Union's requirements according to Directive 2002/96/EC on waste electrical and electronic equipment (WEEE). For information about recycling options, check the Support/Service section of the Tektronix Web site ([www.tektronix.com](http://www.tektronix.com)).

### Restriction of Hazardous Substances

This product has been classified as Monitoring and Control equipment, and is outside the scope of the 2002/95/EC RoHS Directive.

## Preface

This manual describes the installation and basic operation of the NetTek YBT250 Field Transmitter & Interference Tester. For more detailed information on individual measurements, tap the underlined link text on measurement screens to open the Online help for those topics.

## Key Features

The NetTek YBT250 is a rugged, multi-standard measurement and interference location tool optimized for field use. Key features include:

- Multi-standard frequency spectrum analyzer
- Interference hunting functions that help find interference quickly
- Spectrogram display for detection and logging of intermittent signals
- Signal strength, AM/FM demodulation, and noise floor measurements
- Scanners for GSM/GMSK/EDGE, UMTS/W-CDMA/HSDPA, cdmaOne, cdma2000, 1xEV-DO, TD-SCDMA, and iDEN signals
- User-defined channels for taking general measurements and channel scans

## Documentation

---

### To read about

### Use these documents

---

Installation and operation (overviews)

*NetTek YBT250 Field Transmitter & Interference Tester Quick Start User Manual.* The quick start user manual contains general information about how to put your instrument into service, guides to user interface controls, and application examples.

---

Help using the application

*Online Help.* The online help is context sensitive, displaying information appropriate for the active screen or the selected help text. (See page 25, *Getting Help.*)

---

## Software Upgrades

Periodic software upgrades may become available. The software is operational only if you have a valid option key for the specific application module and serial number.

To check for upgrades:

1. Go to the Tektronix Web site ([www.tektronix.com](http://www.tektronix.com)).
2. Click **Software Downloads** on left side of the screen to link to the Software Downloads Web page.
3. Enter the product name or model number in the **Search by keyword** field and click **Go**.
4. Scroll through the list and select the appropriate link for your instrument to show more information or to download the software.

The instructions to perform the software upgrade are in the readme.txt file that is part of the software download.

## Conventions Used in This Manual

The following icons are used in this manual:

Sequence  
Step



Front panel  
power



Connect  
power



## Preventing Personal Injury from Lightning



---

**WARNING.** *To prevent personal injury from the effects of lightning, exercise the following precautions when using this product:*

---

### Before connecting this product to any source

- Check your local weather forecast for the possibility of thunderstorms or lightning.
- If weather conditions could allow thunderstorms or lightning to develop, be sure to visually check the sky and weather conditions in your area frequently.
- If you can hear thunder or if you see lightning, do not connect this product to any source which may be exposed to the effects of lightning.
- Use your own good judgement and common sense. You must protect yourself from the effects of lightning.
- You must assume that hazardous voltages will be present on exposed surfaces of this product if it is connected to a source exposed to lightning. The insulation of this product will not protect you from these hazardous voltages.

## Do not connect this product to any source which might be subject to the effects of lightning

If thunderstorms or lightning are in your vicinity:

- When weather conditions that could lead to lightning activity exist in your area, ***you could be at risk of a lightning strike*** before the cloud is close enough for you to hear thunder or see lightning.
- When lightning strikes a structure or facility, current travels through rebar, concrete, pipes, cables, vent stacks, and electrical system.
- Lightning can induce electric and magnetic fields into structures and portions of wiring. The length of a conductor affected by the magnetic field of a lightning strike may exceed two miles.

## Be alert and aware of the effects of lightning

- When lightning strikes a conductor, which in turn introduces the current into an area some distance from the ground strike point, equipment can be damaged and personnel injured if they become an indirect path in the completion of the ground circuit.
- Conductors such as the braided shields of cables or unshielded wires will have significant transient currents flowing in them in regions exposed to the electric field effect of lightning.
- Induced voltages may cause breakdown of insulation in wiring at connectors and in electrical components or breakdown of air.





# Installation

Carefully unpack your instrument and verify that it includes the standard accessories.

## YBT250 Standard Accessories

<b>Accessory</b>	<b>Tektronix part number</b>
NetTek YBT250 Field Transmitter & Interference Tester Application Module	YBT250
<i>NetTek YBT250 Field Transmitter &amp; Interference Tester Quick Start User Manual</i>	071-1901-XX
<i>NetTek YBT250 Field Transmitter Tester/RF Scout Interference Hunter installation software</i> CD-ROM	063-3476-XX
BNC Connector cover (2)	200-0678-XX
N Connector cover (1)	200-4696-XX
Spacer (1)	016-2464-XX

Your instrument may also include optional accessories. Verify that the optional accessories you ordered are included with your instrument. For a current list of accessories, upgrades, and options, including service options, available for your instrument, visit the Tektronix Web site, [www.tektronix.com](http://www.tektronix.com).

## Operating Considerations

Dimensions (installed on Y400)	Height: 25 cm. (9.75 in) Width: 33 cm. (13 in) Depth: 9 cm. (3.5 in)
Weight	1.42 kg (3.13 lbs) module only
Temperature Range	Operating: 0 °C to +50 °C specified performance, -10 °C to +50 °C typical Nonoperating: -40 °C to +60 °C
Humidity	Operating: 5% to 95% Relative Humidity (RH), noncondensing: up to +30 °C Nonoperating: 5% to 45% Relative Humidity (RH), noncondensing: +30 °C up to +50 °C
Altitude	Operating: Up to 4,600 m (15,092 ft.) Nonoperating: Up to 15,240 m (50,000 ft.)
RF Signal Input	Input frequency range: 30 MHz to 2500 MHz Coupling: AC Input impedance: 50 $\Omega$ (nominal) Maximum input power without damaging instrument: 50 W CW or peak envelope power

## Cleaning

- Clean the exterior surfaces of the instrument with a dry lint-free cloth or a soft-bristle brush.
- Use a cloth or swab moistened with deionized or distilled water, or a 75% isopropyl alcohol solution for more stubborn stains, to clean the instrument or touch screen; use just enough moisture to dampen the cloth or swab.
- Use a gentle amount of force when cleaning the touch screen.



**CAUTION.** *Do not get moisture inside the instrument during exterior cleaning.*

*Do not wash the front-panel On/Standby switch. Cover the switch while washing the instrument.*

*Do not spray liquids directly on the instrument or touch screen.*

*Do not use abrasive cleaners, or chemical cleaning agents that contain benzene, toluene, xylene, acetone, or similar solvents; they can damage the instrument or touch screen. Do not use commercial glass cleaners to clean the touch screen.*

*Do not scrub the touch screen with excessive force while cleaning.*

---

## Connecting the AC Adapter

1. Lift the instrument strap to expose the power adapter connector.
2. Connect the AC power adapter to the instrument.

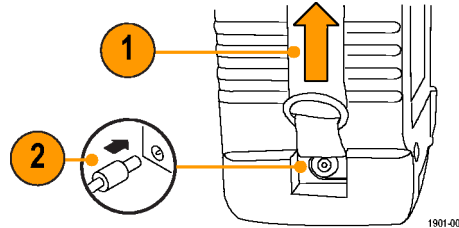

3. Connect the AC adapter to a properly-grounded AC power source using the provided power cord.

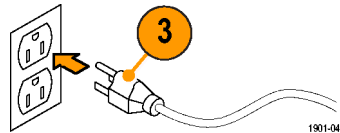

4. Charge the batteries before using the instrument on battery power for the first time. (See page 5, *Charging the Batteries*.)

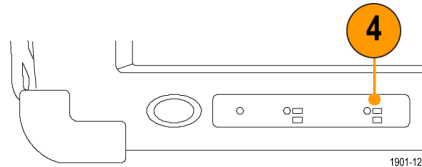

## Charging the Batteries

Charge the batteries before using the instrument on battery power for the first time. Batteries are partially charged and calibrated at the factory. A calibrated battery allows the instrument to more accurately estimate how long the application modules can operate before the instrument automatically powers off. The front-panel BATTERIES charge status indicator turns off when charging is complete.

### Approximate charge time

Number of batteries	Instrument powered on	Instrument powered off
1	8 hours	3 hours
2	16 hours	6 hours

---

**NOTE.** *These are typical numbers for batteries that are low but not completely discharged. Newer-model instruments can contain higher-capacity batteries, resulting in increased run time and longer charge time.*

---

For more information on battery charging, battery calibration, and instrument power management, see the instrument Online help: **Start > Help > Tektronix Basics > Power Management.**

## Powering On and Off the Instrument, and Functional Verification

1. Tap the **On/Standby** button to power on the instrument.

The instrument WindowsCE Status bar shows the Battery icon when the instrument is operating on battery power and the External Power Connected icon when the instrument is operating with an external adapter.

To power off the instrument, tap the **On/Standby** button again.

For information on the instrument on/standby power modes, see the Online help: **Start > Help > Tektronix Basics > Shutting Down the Instrument.**

2. For functional verification, watch the screen. Verify that the instrument does not display any power-on diagnostic error messages.

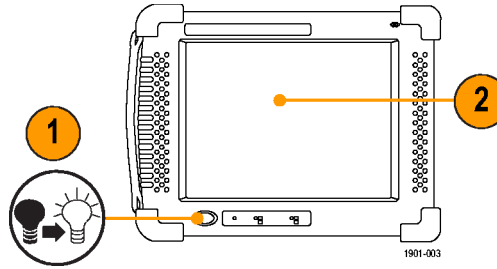

## Touch Screen Concepts

The instrument user interface is based on touch-screen technology. Instead of using physical button and knob controls to select functions, set values, and take measurements, you tap (touch) virtual controls on the instrument screen. Virtual controls behave the same way as physical controls.

The following are touch screen terms used in this manual:

<b>Term</b>	<b>Description</b>	<b>Equivalent mouse operation</b>
Stylus	The physical object you use to touch the screen. A stylus is either your finger or an appropriate plastic-tipped stylus. Do not use any metal-tipped objects or pens for a stylus, as they can damage the touch screen.	The mouse pointer.
Tap	Touch the screen briefly with the stylus. Selects the item on the screen.	The left mouse button.
Drag	Press gently on the screen with the stylus, drag the stylus to a new position, and then raise the stylus from the screen. Moves an item or selects an area.	Drag (hold down the left mouse button, move the mouse, and then release the button).

## Calibrate the Touch Screen

Before using the instrument for the first time, calibrate the touch screen display to respond correctly to your taps.

1. Tap **Start** > **Settings** > **Control Panel** to open the Control Panel screen.

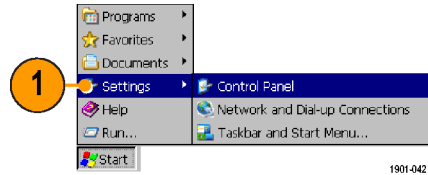

2. Double-tap the **Stylus** icon on the Control Panel screen.



3. In the Double-Tap tab, double-tap the checkerboard grid at a comfortable speed with your stylus or finger to set the tap rate.
4. Double-tap the test icon to verify your settings.

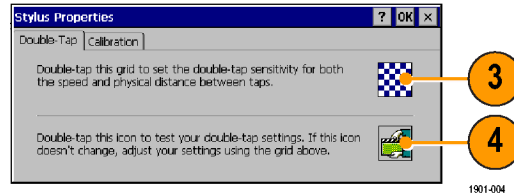



5. Tap the **Calibration** tab and read the instructions.
6. Tap the **Recalibrate** button to open the Cursor Position target screen.

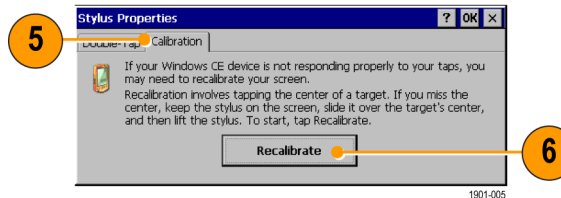

7. Follow the target screen instructions. When the position target disappears, touch anywhere on the screen to return to the Calibration tab.

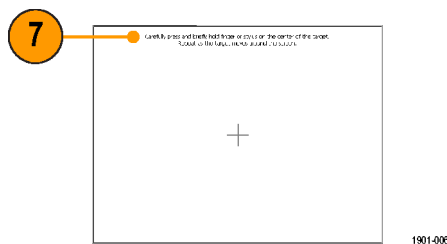

8. Tap **OK** to save calibration settings.

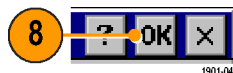

## Starting the YBT250 Application

Use either of the following methods to start the application:

- Double-tap the **YBT250** icon on the instrument screen
- Select **Start > Programs > NetTek > YBT250**

The instrument opens the YBT250 application. The Microsoft WindowsCE taskbar displays a button for each running application. To bring the application to the front of the screen, tap the **YBT250** button in the taskbar.

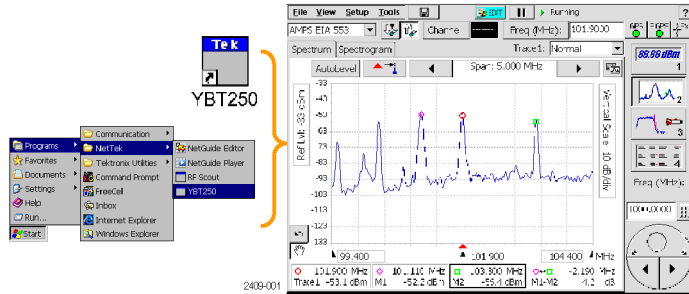

# Setting Display Colors

You can change the color scheme used in the instrument display. The color schemes optimize the display colors for use in different environments (outdoors or indoors) and for better printing quality on black and white (monochrome) printers.

- 1. Select **Tools > Options**.

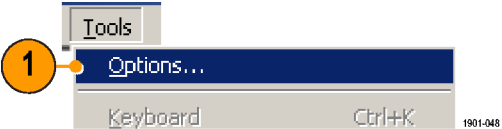

- 2. Tap the **Preferences** tab.
- 3. Tap the **Color Scheme** list field and select a display color scheme.
- 4. Tap **OK**.
- 5. Select **File > Exit** to close the application.
- 6. Restart the application to enable the changed color scheme.

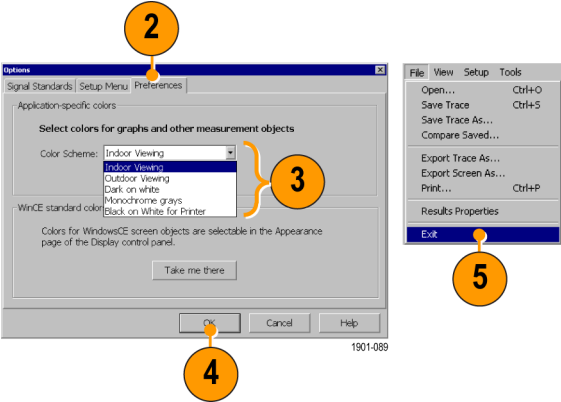

## Enabling Signal Standards

Before you begin using the instrument, you must enable (select) the signal standards that you want to measure. You can only take measurements on enabled standards.

1. Select **Tools > Options**.

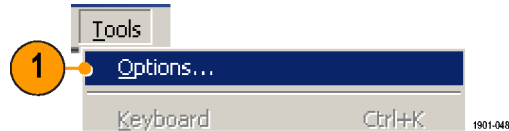

2. Tap the **Signal Standards** tab.

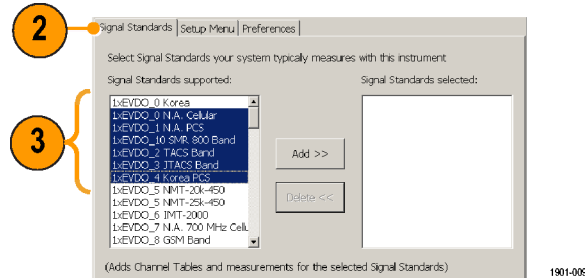

3. Tap the name of the standard in the **Signal Standards supported** list that you want to enable. Drag the stylus to select two or more contiguous standards.

4. Tap the **Add >>** button to add the selected standard(s) to the **Signal Standards selected** list.
5. Tap **OK**. The enabled standards are now selectable from the main window Signal Standards drop-down list.

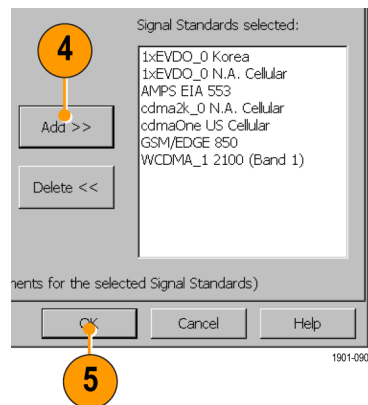

---

**NOTE.** Limiting the number of enabled standards to just those that you regularly test makes it easier and faster to select a standard from the Signal Standard drop-down list.

---



# Getting Acquainted with Your Instrument

## Instrument Elements

1. NetTek Y400 Analyzer Platform.
2. Battery compartment.
3. NetTek YBT250 Application Module.
4. Input/Output ports. (See page 17, *Input/Output Connectors (NetTek Y400 Platform)*.)
5. PCMCIA card ports.
6. Power and Status panel. (See page 16, *Power On/Standby and Status Panel*.)
7. External adapter power connector. (See page 4, *Connecting the AC Adapter*.)
8. Touch screen.

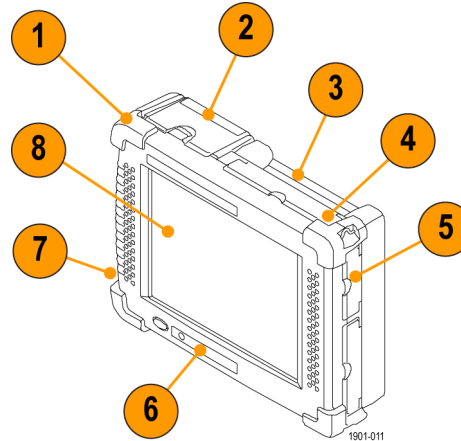

## Power On/Standby and Status Panel

1. Power On/Standby button. Push to power on or off the instrument. For more information, access the online help: **Start > Help > Tektronix Basics > Shutting Down the Instrument.**
2. Reset button. Performs a hardware reset; all programs and data loaded into volatile memory are erased. Generally only used to recover from a system lock-up. Use a thin probe to push the reset button.
3. Power/Display status. Green indicates that the instrument is powered on. Amber indicates that the instrument is powered on but the display is turned off (to conserve power).
4. Battery status. Green indicates that the instrument is connected to an external power source and is charging installed batteries. Red indicates a low battery. No color indicates that the batteries are charged.

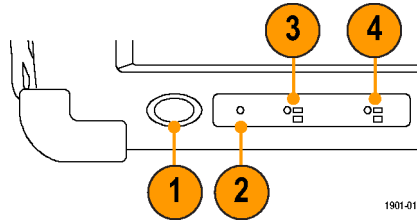



## Input/Output Connectors (NetTek Y400 Platform)

1. Microphone input
2. Headphone jack
3. Ethernet connector (RJ-45)
4. Serial RS-232 connector
5. PS/2 keyboard connector
6. USB Host connector
7. USB Slave connector

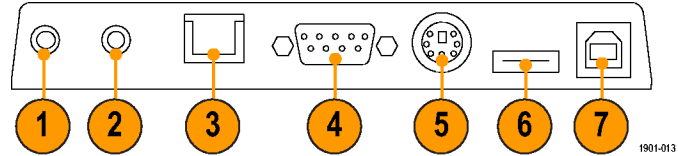

See the *Y400 NetTek Analyzer Setup Reference* document (Tektronix part number 071-1430-XX) for more information on the NetTek Y400 Analyzer Platform.

## NetTek YBT250 Module Signal Connectors

1. Timing Input. Connects to an external timing reference signal, such as a BTS Even Second Clock signal, or the timing signal from a Tektronix YBGPS1 GPS Timing Reference.
2. Frequency Reference Input. Use an external frequency reference signal to improve measurement accuracy.
3. RF Input. The RF Input connects the RF input signal source or measurement antenna to the instrument.

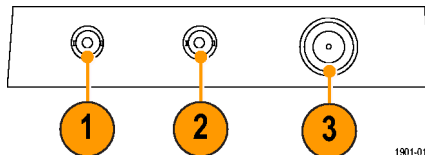

## Microsoft WindowsCE Elements

The Microsoft WindowsCE user interface is similar to other Microsoft Windows operating systems. You use standard Microsoft Windows operations to start (run) applications, select and move objects, and open folders or files. For more Microsoft WindowsCE information, access the online help: **Start > Help > WindowsCE Basics**.

The Status area, located at the bottom right of the screen, contains icons that display important information about the instrument power status. For an explanation of all status area icons, access the online help: **Start > Help > WindowsCE Basics > Understanding Taskbar Icons**.





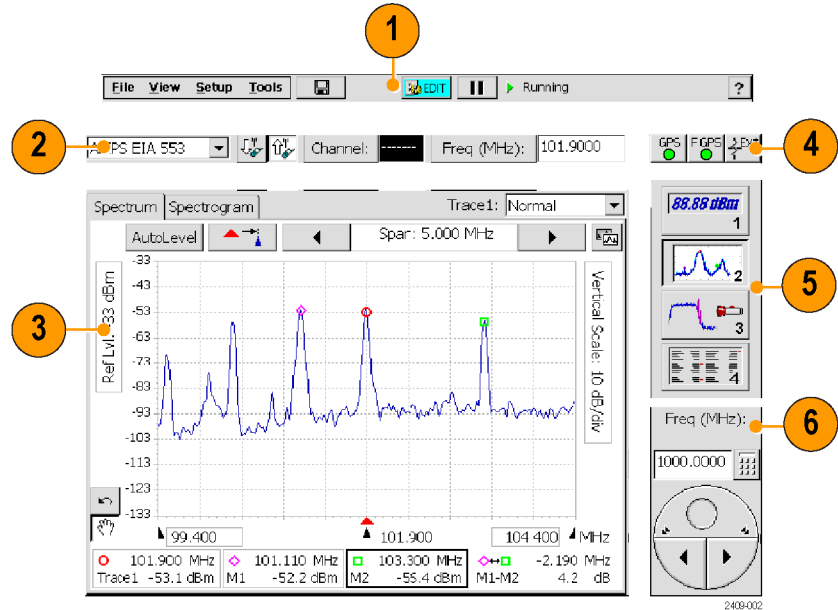

## The User Interface

- 1. Command bar.** (See page 20, *The Command Bar*.)
- 2. Tuning controls.** (See page 21, *The Tuning Controls*.)
- 3. Measurement results.** Shows the waveform displays and measurement results. The appearance of this area changes depending on the selected measurement mode and measurement type.
- 4. External signal status buttons.** (See page 22, *The External Signal Status Buttons*.)
- 5. Measurement mode buttons.** (See page 23, *The Measurement Mode Buttons*.)
- 6. Parameter entry controls.** (See page 24, *The Parameter Entry Controls*.)

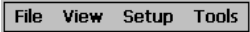



## The Command Bar

Contains the application menus, as well as buttons for saving measurement results, opening the application setup dialog box, and running/pausing the application.

Element	Description
	Menus. See the Online help topic <i>Menus</i> for information about the menu functions.
	Save Results button. Saves the current measurement acquisition to a file. See the Online help topic <i>The Save &amp; Export Tab</i> for how to set file save parameters.
	Edit button. Opens the Setup dialog box that contains instrument settings tabs. See the Online help topic <i>Setup Tabs</i> for information on the setup dialog tabs.
	Open button. Shows the Open dialog box that lists saved instrument setup files to load and configure instrument settings. See the Online help topic <i>The Setup Menu Tab</i> for directions on how to switch the button between the Edit and Open modes.
	Run/Pause button. Runs or Pauses the current measurement acquisition.
	Help button. Opens the online help. Online help is context-sensitive and normally displays a help topic related to the current measurement mode or screen. If the current screen is not context-sensitive, the instrument opens the Online help at the main help menu. Use the index, or do a word search, to locate specific information.





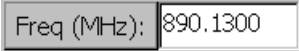

## The Tuning Controls

Selects the signal standard, signal direction (uplink or downlink), measurement channel, and measurement frequency.

Element	Description
	<p>The Signal Standard drop-down list displays the enabled signal standards from which you select a standard to measure. (See page 12, <i>Enabling Signal Standards</i>.)</p>
	<p>The Downlink and Uplink buttons change the Freq (MHz) setting to the forward link (downlink) or reverse link (uplink) frequency of the current signal standard and channel. For W-CDMA signals, these buttons set the corresponding forward or reverse channel number.</p>
	<p>The Channel button sets the channel number. The field next to the button shows the current channel number. Tapping the button opens the numeric keypad, with which you enter a channel number.</p> <p>The current signal standard defines the available channel numbers. Setting the channel number sets the instrument measurement frequency to the appropriate value for the selected signal standard and up or downlink mode setting.</p>
	<p>The Freq (MHz) button sets the Measurement Frequency. The field next to the button shows the frequency. Tapping the button opens the numeric keypad, with which you enter a frequency value.</p>

## The External Signal Status Buttons



Indicates status and sets GPS, measurement reference frequency source, and input signal attenuation or amplification values.

Element	Description
	The GPS status button indicates the GPS signal lock status of an attached GPS receiver. The color indicates the GPS receiver signal lock status. Tap this button to open the GPS setup tab. See the Online topic <i>The GPS Tab</i> for more information.
	The Measurement Reference Frequency status button indicates the measurement frequency reference source. Tap this button to open the Inputs tab. Use this button if you connect an external measurement reference frequency source to the instrument.  The available measurement reference frequency sources are the internal instrument frequency reference (F INT), an external reference (F EXT), or a GPS-derived timing reference from the Tektronix YBGPS1 GPS Timing Reference (F GPS). See the Online topic <i>The Inputs Tab</i> for more information.
	
	
	The RF Input Signal Gain/Loss status button shows the external attenuator or amplifier status. Tap this button to open the Inputs tab where you can set the input signal amplification or attenuation values. Use this button if you connect an attenuator or amplifier to the input signal. See the Online topic <i>The Inputs Tab</i> for more information.
	
	

2409-064

## The Measurement Mode Buttons

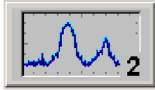
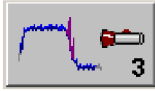
The Measurement Mode buttons select the type of measurement or operation to perform.

Element	Description
 2409-003	Select the Signal Measurements button to take signal measurements including RF power, signal quality, occupied bandwidth, carrier frequency, power vs. time, and others.
 2409-004	Select the Spectrum Measurements button to take spectrum and spectrogram measurements.
 2409-005	Select the Interference Measurements button to take signal strength, audio demodulation, noise floor, EMF, and signal scanner measurements.
 2409-006	Select the Measurement Sequencer button to display multiple measurements.

## The Parameter Entry Controls

The Parameter Entry controls (keypad and knob) let you enter or change numeric values in selected fields. You can use either tool to enter or change a value.

### Element

### Description



The input control field shows the label for the field and the current value of the selected field or object.



Tap the keypad button to display a keypad in which to enter a value in the selected field. The keypad content changes to show the available entry functions for the selected item.

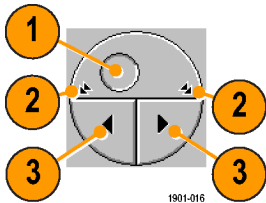

The knob control lets you scroll through and select from all available values.

1. Drag the knob circle left or right to quickly scroll through all available values and select a value.
2. Tap the arrows on the top half of the knob icon to step the value in large increments. The increment value depends on the value type (channel or frequency).
3. Tap the arrows on the bottom half of the knob icon to step the value in single unit increments.



## Getting Help

The application includes a comprehensive Online help system. You access Online help using the following methods:

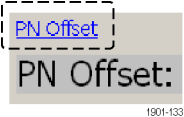
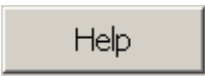
Online help element	Description
	<p>Help button. Located at the top right of the screen, this button is available all the time. Tap this button to display a help topic that is relevant to the current measurement screen.</p> <p>If the current screen is not context-sensitive, the application opens the Online help at the main help menu. Use the index link, or do a word search, to locate specific information.</p>
	<p>Help link text. On measurement screens, underlined blue text is help link text. Bold help link text at the top of a measurement screen opens a topic describing how to take that measurement. Help link text that is located next to a measurement or setting opens a topic relevant to that particular measurement or setting.</p>
<p><a href="#">Contents</a> <a href="#">Index</a></p>	<p>Online help Content and Index links. Every Online help topic includes a Contents and Index link. If the topic does not contain the information you were seeking, use these links to locate specific information.</p>
	<p>Tab or dialog box help button. This button is displayed at the bottom of many setup tabs or dialog boxes, and opens an Online help topic relevant to that tab or dialog box.</p>



# Operating Basics

## Setting Up to Take a Measurement

Perform the following steps to set up the instrument to take a measurement. These steps apply for most types of measurements.

1. Connect a signal to the instrument.
2. Tap the **Signal Standard List** arrow button to open the signal standard list.
3. Tap a signal standard to select it. This signal standard is used for measurements until you change to a different signal standard. (See page 12, *Enabling Signal Standards*.)

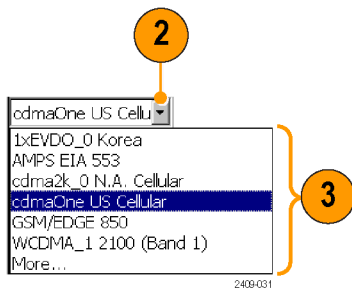

4. Tap the appropriate signal **Uplink** or **Downlink** button for the measurement that you are taking.

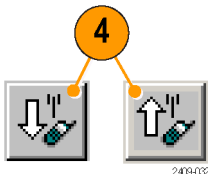

### Entering a Channel:

**NOTE.** You only need to enter a channel or a frequency; you do not need to enter both values.

5. Tap the **Channel** button to open the keypad.

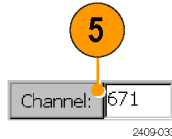

6. Enter a channel number.

7. You can also tap the **List** button to display a list of available channels from which to select a value. Channel numbers are defined by the current signal standard.  
If there is a corresponding frequency for the entered channel number, the instrument displays that frequency in the Freq (MHz) field.

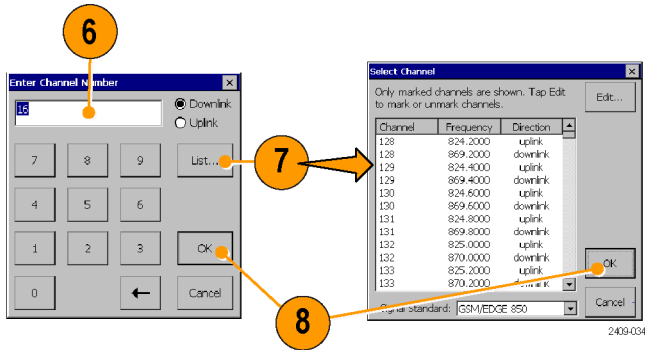

- If you enter a channel number outside the valid range, the instrument sets the channel number to the closest valid number.
8. Tap **OK** to close the keypad or channel list and set the channel value.

**Entering a Frequency:**

**NOTE.** You only need to enter a channel or a frequency; you do not need to enter both values.

9. Tap the **Freq (MHz)** button to open the keypad.

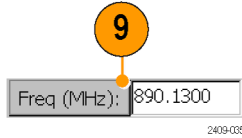

10. Use the keypad to enter a frequency value. This sets the center frequency of the measurement. If there is a corresponding channel number for the entered frequency, the instrument displays that channel number in the Channel field.

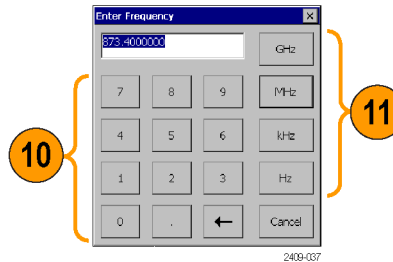

11. Tap a frequency unit button (such as GHz or MHz) to close the keypad and set the frequency value.

**Selecting a Measurement Mode:**

- 12. Tap a measurement mode button. (See page 23, *The Measurement Mode Buttons.*)
- 13. For Spectrum and Interference measurements, select the tab of the measurement that you want to take.

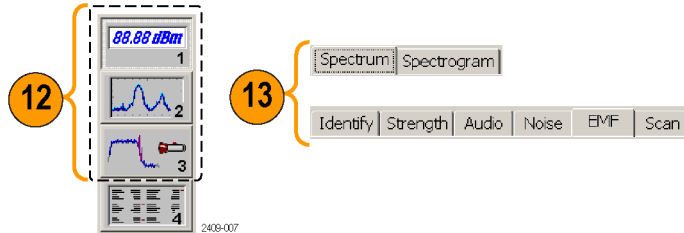

- 14. For Signal measurements, tap the **Select Measurement** button, then tap the measurement that you want to take.

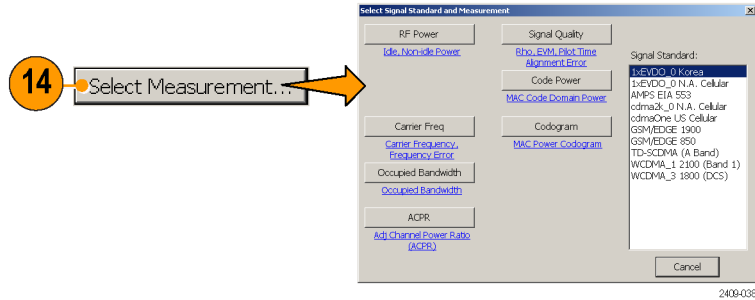

### Setting Additional Measurement Parameters:

15. Tap the **Edit** button to open the **Setup** dialog box.
16. Tap the tab of the measurement parameters that you want to set.
17. Select or enter the measurement parameter values.
18. Tap **OK** to close the Setup dialog box and enable the measurement parameter settings.

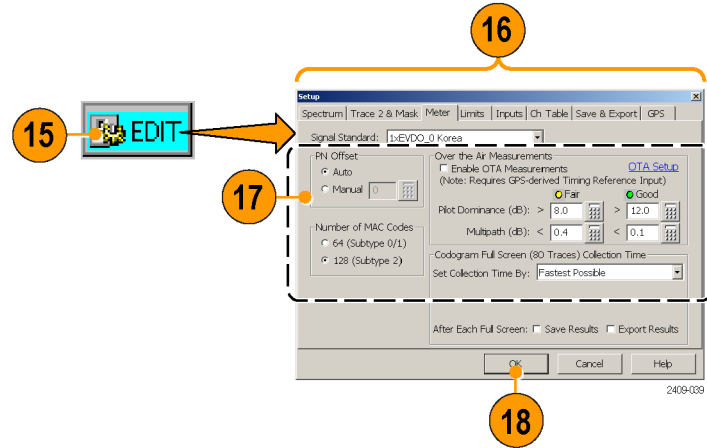

# Signal Measurements

## Taking a Signal Measurement

Signal measurements include RF channel power, peak/average, carrier frequency, occupied bandwidth, signal quality, code power, codograms, and pilot power. Available measurements depend on the current signal standard.

1. Set the instrument to measure a signal of interest. (See page 27, *Setting Up to Take a Measurement.*)
2. Tap the **Signal Measurement** button.
3. Tap the **Select Measurement** button to open the **Select Signal Standard and Measurement** dialog box.
4. Tap the measurement button for which you want to take measurements. The instrument opens the selected measurement screen.

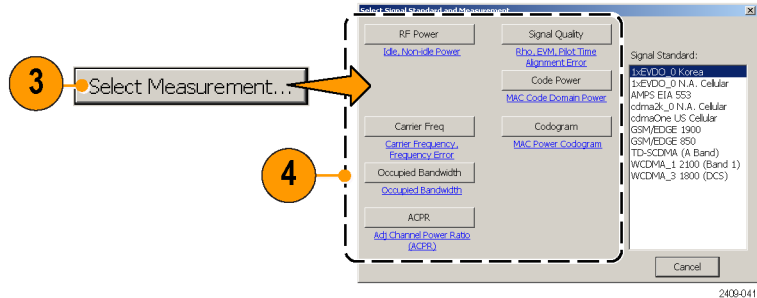
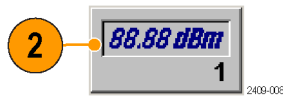



- 5. Make any necessary setting changes on the measurement screen (if available). For example, the cdma2000 Signal Quality measurement lets you select the signal type to use for measuring Signal Quality (Pilot only or Auto detect active codes).

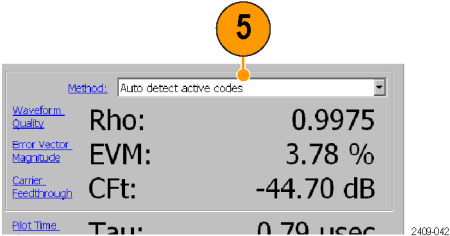

- 6. Tap the **Edit** button to open the **Setup** dialog box and set additional measurement parameters in the dialog box tabs. Available parameters depend on the current signal standard and measurement type. Not all measurements have setup parameters.

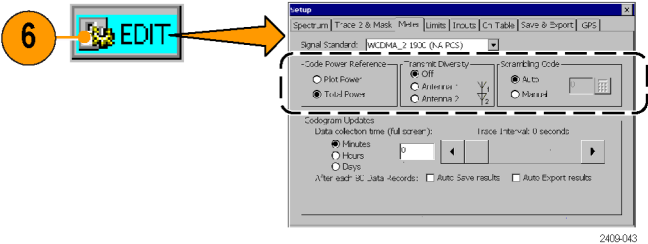

## Spectrum Measurements

### Displaying a Spectrum Waveform

1. Set the instrument to measure a signal of interest. (See page 27, *Setting Up to Take a Measurement.*)
2. Tap the **Spectrum** button.
3. Tap the **Spectrum** tab.
4. Tap the **AutoLevel** button.
5. Tap the **Span** controls to change the displayed frequency span to show the waveform area of interest.

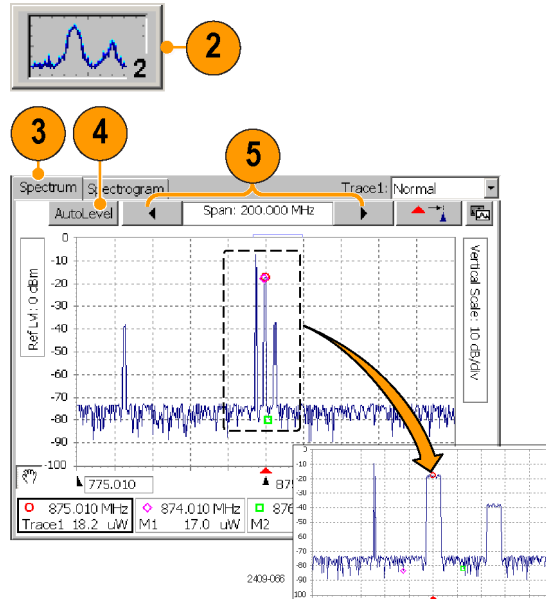

6. Tap the **Ref Lvl** field or the **Vertical Scale** field to select it.
7. Use the Parameter Entry controls to enter or change the scale setting.
8. Use markers to take measurements between different parts of the waveform. (See page 36, *Spectrum Waveform Markers*.)

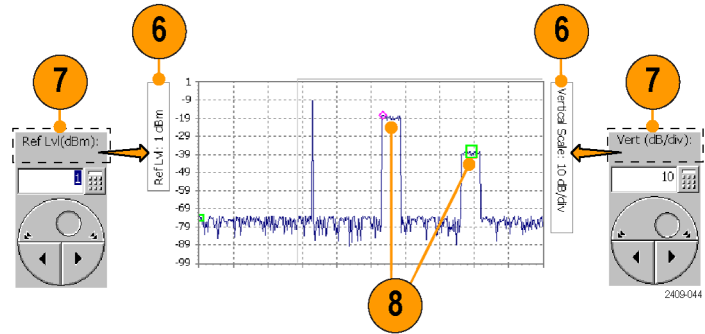

---

**NOTE.** Tap the **Edit** button to open the **Setup** dialog box and set additional measurement parameters. Available parameters depend on the current signal standard and measurement type. Not all measurements have setup parameters.

---

## Spectrum Waveform Markers

Markers are visual icons that you position on a spectrum waveform to measure signal frequency and level values. You use the markers to measure the value at a particular point on a waveform or to measure the difference between two markers (Marker 1 minus Marker 2). The markers follow the waveform level changes.

Each marker icon has an associated marker readout, displayed at the bottom of the Spectrum display. The marker readout shows the marker icon symbol, the marker name, and the frequency and level values for the marker.

There are three markers available: the Trace marker (Trace), M1, and M2. The Trace marker changes the measurement frequency to the location you select on the waveform. The M1 and M2 markers read the waveform frequency and level at the location they are placed.

### Turning Markers On and Off.

1. Tap **View**.
2. Tap **Markers** to turn marker display on or off.
3. Markers consist of a marker icon that is placed on a waveform, and a marker readout that shows the signal frequency and level at the marker icon position.

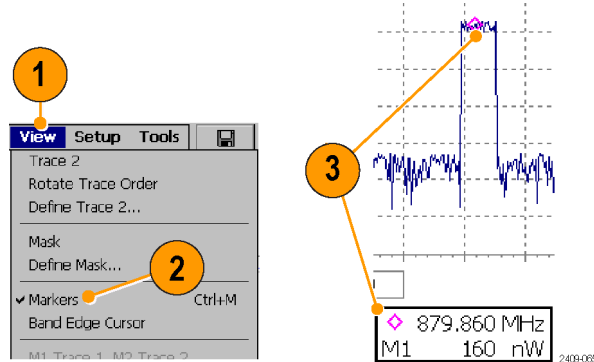

### Adding or Moving a Marker on a Waveform.

1. Tap the marker readout of the marker that you want to add or move on the spectrum waveform. The marker readout border darkens to indicate that it is selected.
2. Tap the waveform where you want to add or move the marker. The marker is positioned on the waveform and the readout shows the signal values at the new location.
3. If necessary, use the Parameter Entry controls to position the marker on the waveform by changing the marker frequency.

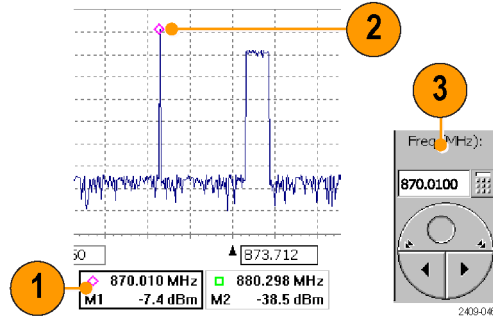

## Comparing Spectrum Waveform Traces

You can compare two live waveforms (derived from the single RF input signal), a live signal and a saved waveform, or two saved waveforms.

### Selecting a Waveform Trace.

1. Tap the **Traces** button to toggle between **Trace 1** and **Trace 2**.

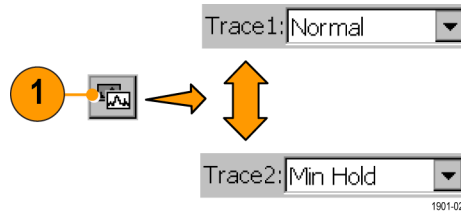

### Comparing Live Waveform Traces.

1. Set the instrument to display the spectrum waveform of interest. (See page 34, *Displaying a Spectrum Waveform.*)
2. Tap the **Traces** button to select **Trace 1**.



3. Tap the **Trace 1** list button and then tap a trace type to select it. The instrument applies the selected operation to the RF input signal and displays the results as the trace 1 waveform.

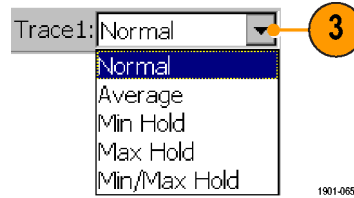

4. Tap the **Traces** button again to select **Trace 2**.



5. Tap the **Trace 2** list button and then tap a trace type to select it. The instrument applies the selected operation to the input signal and displays the result as the trace 2 waveform, along with the trace 1 waveform. The figure shows Trace 1 as a **Normal** waveform and Trace 2 as a **Min Hold** waveform.

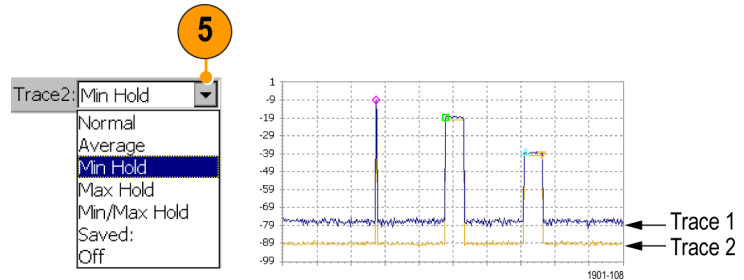

6. To make measurements between the waveforms, use the **View** menu to set which markers are on which trace.

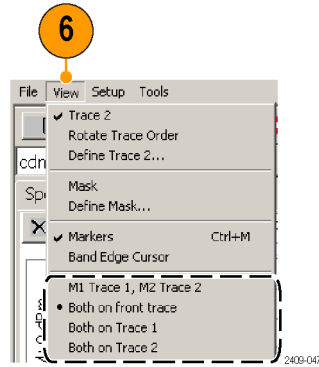



## Comparing a Live Waveform to a Saved Waveform.

**NOTE.** The current instrument measurement settings must match the instrument settings used to capture the saved waveform.

1. Set the instrument to display a spectrum waveform of interest. (See page 34, *Displaying a Spectrum Waveform.*)
2. Tap the **Traces** button to select **Trace 1**.
3. Tap the **Trace 1** list button and then tap a trace type to select it.

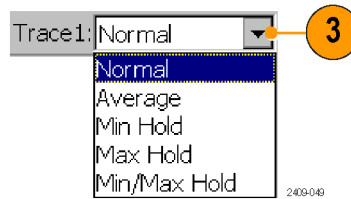

4. Tap the **Traces** button to select **Trace 2**.



5. Tap the **Trace 2** list button and tap **Saved** to open the **Trace 2 & Mask** setup tab.

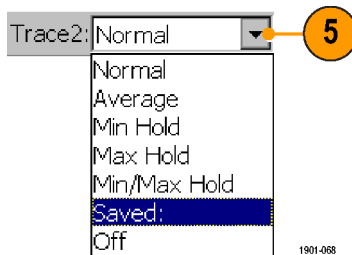

6. Tap **Saved Trace**.

7. Enter a file path and name of a saved waveform file, or tap the **Browse** button to navigate to and select the saved waveform to open.

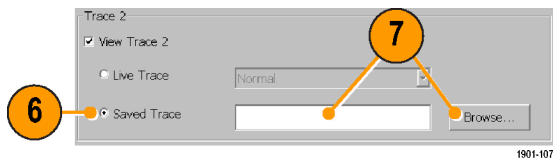

8. Tap **OK**. The instrument displays the saved waveform as the Trace 2 waveform. You can use markers to make measurements between the waveforms.



## Comparing Two Saved Waveform Traces.

**NOTE.** Waveform traces are saved with the settings in effect at the time the trace is saved. When a saved trace is displayed, the stored settings values are shown for reference, though no actual instrument settings change. As soon as you tap the **Run** button to return to making new acquisitions, the display settings are restored to what they were before the saved trace was opened.

1. Select **File > Compare Saved**.
2. Navigate to and select the first waveform file to load.
3. Tap **OK** to open the **Select second result file to compare** dialog box (it looks exactly the same as the first dialog box).
4. Navigate to and select the second waveform file to load.
5. Tap **OK** to select the second file and close the dialog box. The instrument displays both waveforms.
6. After viewing the waveforms, tap the **Run** button to return the instrument to taking measurements.

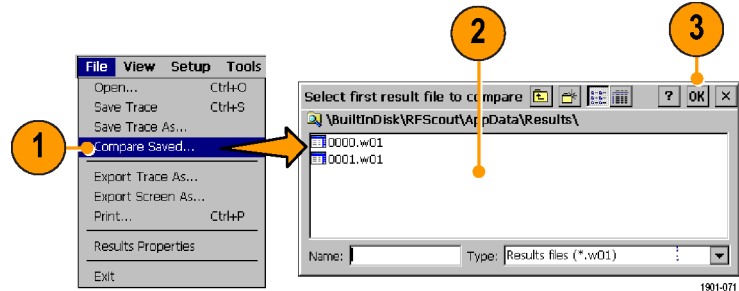

## Displaying a Spectrogram

A spectrogram shows how the signal level changes over time. It can be very useful in finding intermittent signal level variations.

1. Set the instrument to display the spectrum waveform of interest. (See page 34, *Displaying a Spectrum Waveform*.)
2. Tap the **Spectrogram** tab. The Spectrogram display updates from the bottom to the top of the display.
3. Tap the **Updates** button to display a dialog box where you can change the spectrogram measurement update rate and enable automatic saving of data when a screen is full (80 data record acquisitions).
4. The Data Record readout shows the time and date stamp of the spectrogram record located at the record cursor (white horizontal line). To change the record cursor position, tap the Data Record field and use the keypad or knob to move the record cursor.

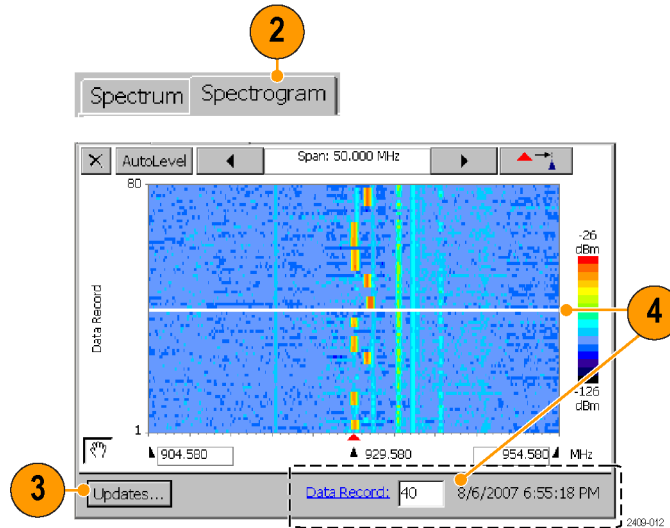

## Interference Measurements

The Interference measurement capabilities provide functions to help identify interference signals, demodulate AM or FM audio signals, assess the strength of an interfering signal, measure the noise floor on receive channels, and display PN offset or scrambling code data for specified channels.



2409-050

Tab	Description
Identify	Display information on the likely modulation type of a selected signal. Identify can differentiate between CDMA, W-CDMA, GSM, IS-136, and analog signal modulation types. (See page 46, <i>Identifying a Signal</i> .)
Strength	Locate an interfering signal by using a directional antenna and listening to an audio tone that corresponds to the signal level. (See page 48, <i>Locating a Signal</i> .)
Audio	Demodulate an AM or FM signal to help identify traffic type. (See page 49, <i>Listening to a Signal</i> .)
Noise	Measure the noise floor on receive channels. (See page 51, <i>Taking a Noise Floor Measurement</i> .)
EMF	Measure RF field strength, such as when assessing the strength of an interfering signal. (See page 52, <i>Measuring EMF</i> .)
Scan	Display PN offset or scrambling code data for specified channels. (See page 54, <i>Channel Scanners</i> .)

## Identifying a Signal

1. Set the instrument to display the spectrum waveform of interest. (See page 34, *Displaying a Spectrum Waveform.*)

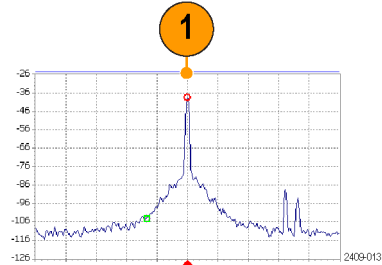

2. Tap the **Interference** button, and then tap the **Identify** tab.

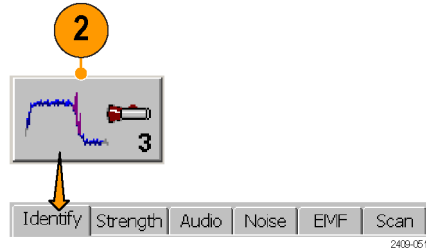

- 3. Tap the trace of the interfering signal to set the measurement frequency. Try to set the measurement frequency to the center of the signal. You can also enter the frequency value.
- 4. The **Specified Channels** list displays any signal standards that have channels defined at the measurement frequency.
- 5. Tap **Measure**. The instrument performs a series of measurements to identify which signal standard the signal's characteristics most closely match and displays possible matches in the **Measurements suggest** results box. The signals are sorted by frequency, with the signal that most closely matches the measurement frequency located at the top of the list. The instrument also lists bandwidth and level information above the Measure button.

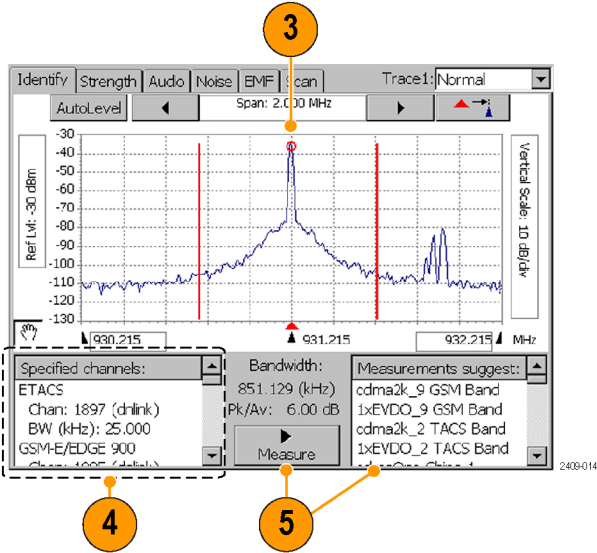

## Locating a Signal

1. Connect a directional antenna to the instrument.
2. Set the instrument to display the spectrum waveform of interest. (See page 34, *Displaying a Spectrum Waveform*.)
3. Tap the **Interference** button, and then tap the **Strength** tab.
4. Tap the trace of the interfering signal to set the measurement frequency. You can use the keypad or knob to adjust the measurement frequency.
5. Point the directional antenna in different directions. As you change the direction of the antenna, the audible tone and beep (if selected), and the Strength bar graph change to indicate signal strength. The signal of interest is located in the direction that results in the strongest signal.
6. Tap **Fast Update** to improve audio tone response, at the expense of a reduced screen update rate.

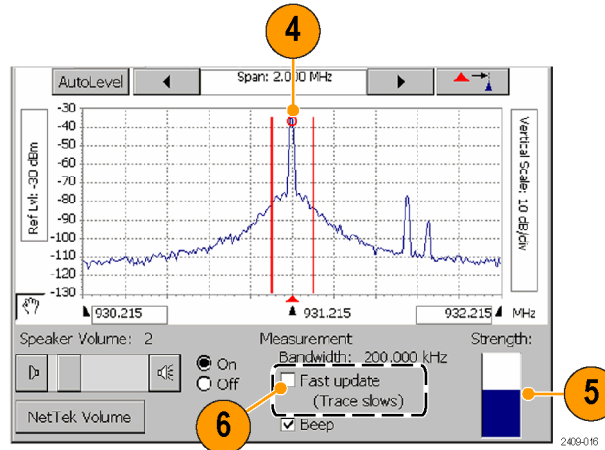
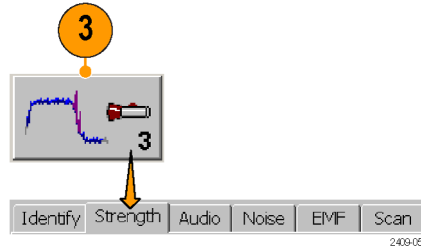



## Listening to a Signal

1. Set the instrument to display the spectrum waveform of interest. (See page 34, *Displaying a Spectrum Waveform*.)
2. Tap the **Interference** button, and then tap the **Audio** tab.

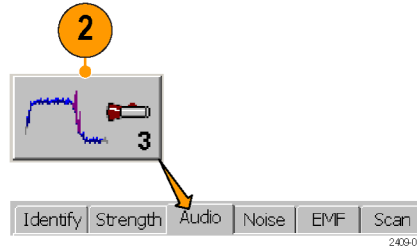

2409-057

3. Tap the trace of the interfering signal to set the measurement frequency. You can use the keypad or knob to adjust the measurement frequency.
4. Tap the different **Demodulation** types and listen to the resultant audio (if any). A station ID can be particularly helpful when the interfering signal is a radio or broadcast television station. You may also be able to discriminate between possible sources by listening to the characteristic sounds of paging, video, control signals or the harmonics of other common signals.

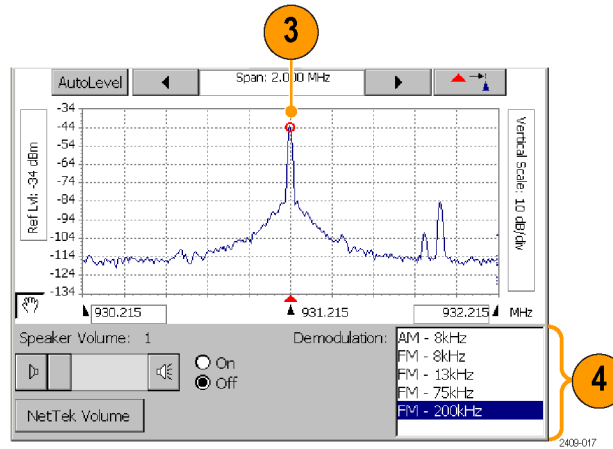

## Taking a Noise Floor Measurement

Noise floor measures all the RF Power coming into the receive antenna within the frequency band of the selected channel. The noise floor is the power integrated across the selected channel. To make an accurate measurement, you must measure the noise floor on a disabled channel (a channel that is not carrying live traffic).

1. Connect a signal from a BTS receiver test port to the instrument.
2. Set the instrument to display the spectrum waveform of interest. (See page 34, *Displaying a Spectrum Waveform*.)
3. Tap the **Reverse** (up) link button.
4. Tap the **Interference** button, and then tap the **Noise** tab.
5. Tap the trace of the interfering signal to set the measurement frequency. You can use the keypad or knob to adjust the measurement frequency.

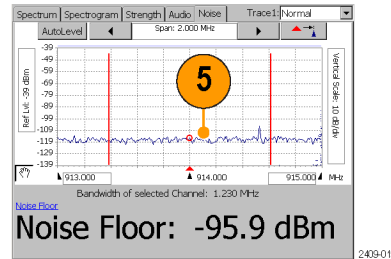
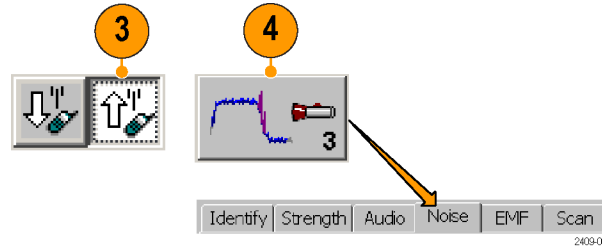

## Measuring EMF

EMF field strength is a measure of the absolute electromagnetic power of a signal at a particular frequency and bandwidth at the antenna, without reference to signal modulation.

1. Connect a hand-held antenna and filter (if used) to the instrument.
2. Set the instrument to display the spectrum waveform of interest. (See page 34, *Displaying a Spectrum Waveform*.)
3. Tap the **Downlink** button.
4. Tap the **Interference** button, and then tap the **EMF** tab.

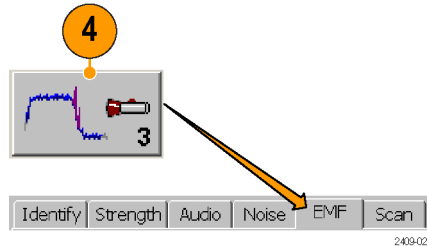
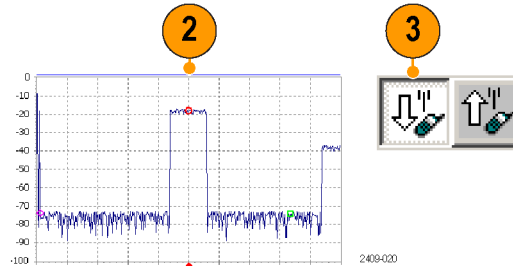

5. Tap the **Averaging** field and use the knob or keypad to enter a time period over which to acquire measurements for the average strength readout.
6. Tap **Restart** to clear and restart the measurement, including measurement averaging.

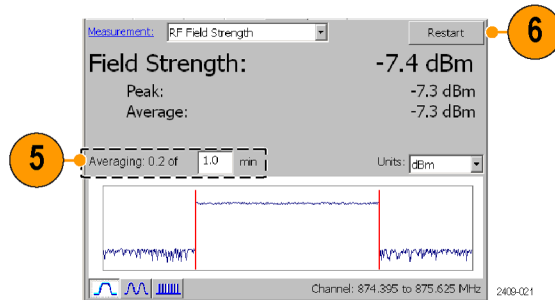

## Channel Scanners

Channel scanner measurements display channel-specific measurements on GSM, cdma200, 1xEV-DO, and W-CMA standards. Scanner measurements are for off-air reception using an antenna, and measure only downlink signals.

1. Connect a hand-held antenna (and filter if used) to the instrument **RF INPUT** connector.
2. Set the instrument to measure a signal of interest. (See page 27, *Setting Up to Take a Measurement.*)
3. Tap the **Downlink** button.
4. Tap the **Interference** button, and then tap the **Scan** tab.

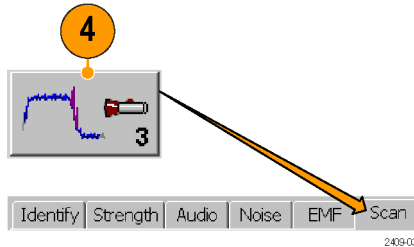

Scanner displays consist of two parts. The upper display is a plot of channel, scrambling code, or PN offset codes and signal strength. The lower display provides more information on individual channels, scrambling code, or PN offsets.

- 5. Use available controls to set measurement functions.

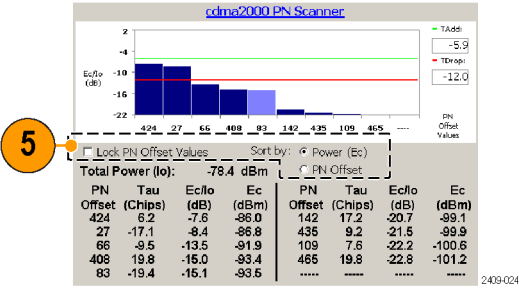

---

**NOTE.** To make accurate measurements, use a receive antenna with a frequency response and bandwidth that is appropriate for the channel you are measuring. Use a high quality, low-loss Band Pass Filter (BPF) to reject signals outside the signal band. If you take measurements near a high-power transmitter, such as commercial TV or radio, a BPF may be necessary for the scanner to produce usable results.

---

**Scanner Tadd/Tdrop Markers.** Tadd and Tdrop are horizontal markers that you can set on 1xEV-DO and cdma2000 PN Scanner measurements to visually indicate add or drop signal power levels. Using these markers lets you quickly identify PN codes that are within defined add or drop ranges. The Tadd/Tdrop horizontal markers are visual aids only, and do not cause the instrument to display warnings when signals are above or below the set levels.

1. Select **View > PN Scanner Tadd/Trop Markers** to display the markers on the scanner measurement graph.

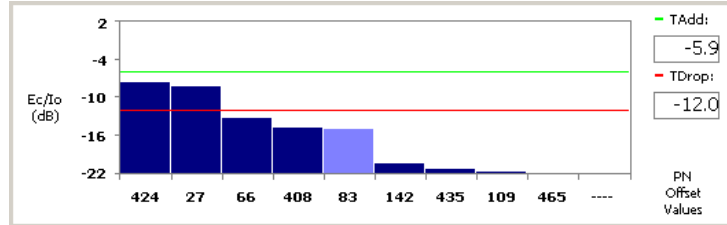

2. Tap the Tadd or Tdrop readout and use the keypad or knob control to change the marker level value.

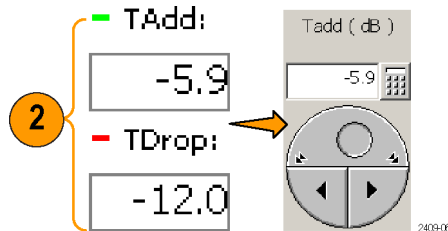



**Custom Scanner Code Labels.** The Scanner Code Label Editor lets you add unique labels to the graphs of 1xEV-DO and cdma2000 PN scanners, and the W-CDMA scrambling code analyzer. Once you have created labels, tapping a bar graph of a PN offset or scrambling code displays the label assigned to that PN offset or scrambling code, directly below the graph. Using labels lets you quickly identify the source of a particular code.

1. Select **View > PN Offset Labels** or **View > Scrambling CodeLabels** to enable viewing scanner labels on the scanner measurement graph.
2. Tap a bar graph plot to display the custom label assigned to that PN offset or scrambling code.

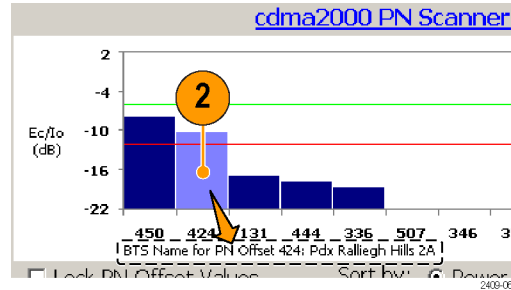

See the Online help topic *Scanner Code Labels Overview* for information on creating, saving and using custom scanner code labels.

## Displaying Multiple Measurements

The Measurement Sequencer mode lets you display one or more signal measurements for a single standard and channel/frequency. The instrument sequences through each of the selected measurements and displays the results on the Sequencer screen.

1. Set the instrument to measure a signal of interest. (See page 27, *Setting Up to Take a Measurement.*)
2. Tap the **Sequencer** button.
3. Tap the **Select Measurements** button.
4. Select which measurements to display in the Sequencer screen, and then click **OK**. Available measurements depend on the current signal standard.

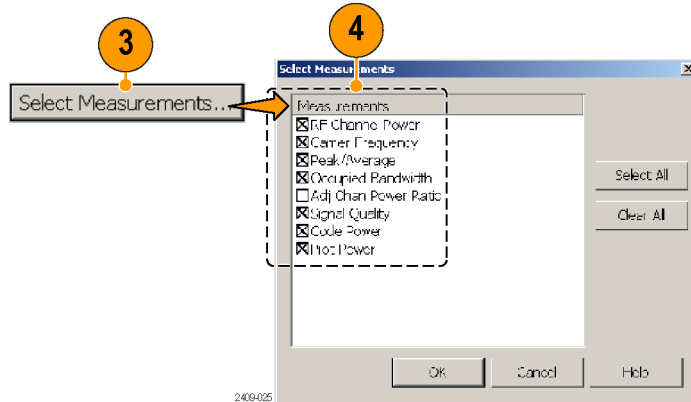
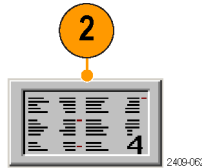

5. The instrument displays the selected measurements, sequentially updating the measurement values.
6. Out-of-limit measurements are marked by a red block with an up or down arrow.
7. Messages may appear in the measurement name gray bar to indicate measurement errors or conditions.

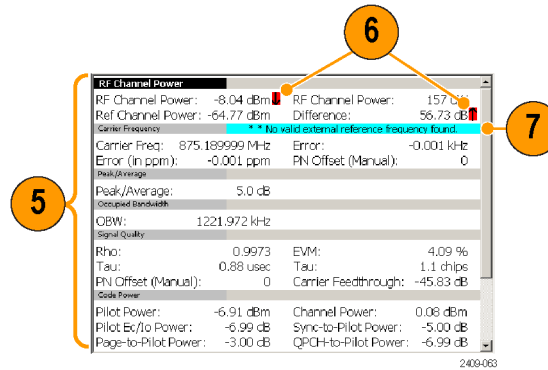

## Saving and Loading Sequencer Measurements and Results

You can save measurement sequences for each standard and then recall these sequences later for reuse. To save a measurement sequence, tap **Setup > Save**, enter a name, and tap **OK**.

You can use the file menu to save, export, or print the numeric Sequencer data, including error information and the timestamp (the time of the last individual measurement taken). Note that if you export a screen, a picture of only what shows on the screen is exported. If there is a scroll bar visible, then some measurement results are hidden and are not exported. To avoid this problem, use **File > Export Results As**, or scroll down and export a second view of the screen.

To load a saved sequence, tap **Setup > Open**, navigate to and select a saved sequence settings file, and tap **OK**.



# Specifications

This section lists the electrical, environmental, and physical specifications of the NetTek YBT250. All specifications are guaranteed unless labeled “typical”. Typical specifications are provided for your convenience and are not guaranteed.

**Table 1: General characteristics**

Characteristic	Description
<b>RF Input</b>	
Input Frequency Range	30 MHz – 2500 MHz
Input Impedance	50 ohms (nominal)
Signal Amplitude for Modulation Measurements	–50 dBm to +30 dBm for CW-like or peak envelope power Measurements may be outside this range but accuracy is not guaranteed
Signal Amplitude for Spectral Display, typical	CW or peak envelope power: –144 dBm to +30 dBm, 200 MHz to 2.0 GHz –142 dBm to +30 dBm, 2.0 GHz to 2.2 GHz –139 dBm to +30 dBm, 2.2 GHz to 2.5 GHz Levels apply when using 100 Hz resolution bandwidth
Input Overload Detect	>1 W (+30 dBm) CW or peak envelope power
Maximum Input Power without Damaging Instrument	50 W CW or peak envelope power
Coupling	AC for all measurements and spectral display modes

**Table 1: General characteristics (cont.)**

<b>Characteristic</b>	<b>Description</b>
Maximum Working Voltage	15 V (DC + peak AC)
Spurious Input Signals	To meet modulation measurement specifications: (Total power of interest - Total power in spurious) > 35 dB or   Center frequency of signal of interest - center frequency of spurious signal   > 1.4 MHz and (Total power of interest - Total power in all spurious) ≥ -3 dB
<b>Frequency Reference Input</b>	
Impedance	50 ohms (nominal)
Frequency Range	Any multiple of 1 MHz up to 15 MHz inclusive, ± 1 ppm Any multiple of 1.2288 MHz up to 19.6608 MHz inclusive, ± 1 ppm 2.048 MHz ± 1 ppm 4.8 MHz ± 1 ppm
Level Range	-15 dBm to +15 dBm
Maximum Input Level without Damage	± 3 V peak continuous
Coupling	AC
Working Voltage	3 V (DC + peak AC)

**Table 1: General characteristics (cont.)**

<b>Characteristic</b>	<b>Description</b>
Lock Time	< 15 seconds
<b>Timing Input</b>	
Impedance	10 k $\Omega$
Minimum High Threshold	2.0 V
Maximum Low Threshold	0.8 V
Minimum High Time	10 ns
Minimum Low Time	10 ns
Maximum Input Level without Damage	$\pm$ 5 V peak continuous
Coupling	DC
Timing Error	$\pm$ 10 ppm
<b>Internal Time Base Characteristics</b>	

**Table 1: General characteristics (cont.)**

<b>Characteristic</b>	<b>Description</b>
Error	<p><math>\pm 0.5</math> ppm drift from 0 °C to 50 °C</p> <p><math>\pm 1.0</math> ppm aging/year</p> <p>Ten minute warm-up period required to meet accuracy specification.</p> <p>Users can connect the External Reference input to a frequency source and obtain a user correction value. This value will be used to correct time base errors in measurements to the accuracy of the external reference. The internal time base will continue to drift with temperature and age as specified above.</p>
<b>Signal Path Characteristics</b>	
Phase Noise	$\leq -75$ dBc/Hz @ 20 kHz carrier offset
Noise Figure	<p>1 kHz resolution bandwidth:</p> <p><math>\leq 10</math> dB, 200 MHz to 2000 MHz</p> <p><math>\leq 12</math> dB typical, 2000 MHz to 2200 MHz</p> <p><math>\leq 15</math> dB typical, 2200 MHz to 2500 MHz</p>
Displayed Average Noise Level (DANL), typical	<p>10 Hz RBW: <math>-152</math> dBm, 200 MHz to 2000 MHz</p> <p>100 Hz RBW: <math>-145</math> dBm, 200 MHz to 2000 MHz</p> <p>1 kHz RBW: <math>-135</math> dBm, 200 MHz to 2000 MHz</p>



**Table 2: Measurement characteristics**

<b>Measurement</b>	<b>Description</b>
<b>External Attenuation</b>	User Selectable ON/OFF Attenuation = -30 dB to +80 dB
<b>Code Domain Power (cdmaOne, cdma2000, W-CDMA)</b>	Measures the power in each of the Walsh codes (64 in cdmaOne, 128 in cdma2000) used in a CDMA signal. Measures the power in each of (up to 512) OVSF codes used in a W-CDMA signal.
Units	dB relative to Pilot Power or Total Power
Resolution	0.1 dB
Accuracy	cdmaOne and cdma2000: $\pm 1$ dB code domain power level $> -20$ dB relative to total power, using the recommended TIA/EIA-IS-97-D pilot level of $-7.0$ dB (20%) relative to total power. W-CDMA: $\pm 1$ dB Code domain power level $> -20$ dB relative to total power, using W-CDMA 3GPP Test Model 3. Reference information: $\pm 2.5$ dB for $-27$ dB $< CDP < -20$ dB relative to total power in band classes 0-6 (cdmaOne, cdma2000). $\pm 2.5$ dB for $-27$ dB $< CDP < -20$ dB relative to total power (W-CDMA).

**Table 3: Spectral analysis**

<b>Characteristic</b>	<b>Description</b>
<b>Measurement Frequency</b>	Sets the measurement frequency of the display. The measurement frequency can be set by either entering a specific frequency or by selecting a channel number.
Units	MegaHertz (MHz) or Channel Number
Resolution	1 kHz 1 channel
Range	30 MHz to 2500 MHz
<b>Frequency Span</b>	Sets the frequency range covered by the spectral display.
Units	kiloHertz (kHz), MegaHertz (MHz)
Resolution	1 kHz
Range	10 kHz to 2470 MHz, continuously variable or 1-2-5 steps
<b>Resolution Bandwidth (RBW)</b>	Width of the resolution bandwidth filter
Units	Hertz (Hz), kiloHertz (kHz), MegaHertz (MHz)
Resolution	Uses 1-3 steps to cover the range
Range	10 Hz to 6 MHz  When in Auto mode, the instrument automatically sets the RBW. The RBW is set as a combination of 1-3 steps at the 1, 2, 5 span settings, and a linear range between 1, 2, 5 span settings, for a nominal value of approximately Span/125.
<b>Reference Level</b>	The power level indicated by the top line of the spectral display
Units	dBm

**Table 3: Spectral analysis (cont.)**

<b>Characteristic</b>	<b>Description</b>
Resolution	1 dBm
Range	-100 dBm to +30 dBm
<b>Spectral Display</b>	
<b>Amplitude</b>	
Units	dB relative to Reference Level
Resolution	0.1 dB
Accuracy	$\pm 1.25$ dB, -20 dBm to +30 dBm $\pm 2.0$ dB, -80 dBm to -20 dBm $\pm 2.75$ dB, -120 dBm to -80 dBm $\pm 5$ dB -134 dBm < Input < -120 dBm, typical
Accuracy specifications apply only for spans less than 1000 MHz and to CW-like signals.	
<b>Vertical Scale Factor</b>	
Units	1 dB to 10 dB in 1 dB increments

**Table 3: Spectral analysis (cont.)**

<b>Characteristic</b>	<b>Description</b>
Display Modes	<p>Normal: updates display with each new result</p> <p>Max Hold: updates displayed point only if new point &gt; old point</p> <p>Min Hold: updates displayed point only if new point &lt; old point</p> <p>Max/Min Hold: displays a bar between Max Hold and Min Hold</p> <p>Average: displays average of N (specified by user) results</p> <p>Reference information: Average is calculated as follows: The last N values are saved in memory; when a new result is available, the earliest result of the N stored values is discarded, the new average is calculated from the stored values. If the number of results is less than N, then all of the results are averaged together.</p>
Number of Averages	$1 \leq N \leq 99$
Spurious Free Dynamic Range (external signal related)	<p>IM3 better than -70 dBc typical, 100 MHz to 2500 MHz</p> <p>2nd Harmonic better than -60 dBc, typical</p>
Residual Spurious Signals	<p>-125 dBm at BTS Rx frequencies (776-794, 806-849, 872-940, 1453-1465, 1525-1549, 1710-1785, 1840-1910, 1920-1980) MHz and GPS frequencies (L1 1570.3-1580.5, L2 1222.5-1232.8, L5 1171.4-1181.6) MHz</p> <p>-115 dBm at BTS Tx frequencies (746-764, 832-834, 840-960, 1477-1513, 1805-1880, 1930-1990, 2110-2170) MHz</p> <p>-95 dBm at frequencies not listed above, except from 1155-1168 MHz: -20 dBm in spans above 10 MHz, 1155 MHz-1175 MHz</p>

**Table 4: Interference analysis characteristics**

<b>Characteristic</b>	<b>Description</b>
<b>Noise Floor Measurement</b>	Measures the interference power that is coming into the receiver antenna for any standard. Measurement defaults to uplink channel when specified by channel number.
Units	dBm
Resolution	0.1 dB
Accuracy	± 3 dB typical
<b>AM Demodulation</b>	Provides an audio output signal after AM demodulation of the user-selected signal to use for identifying a signal.
Measurement Frequency	30 MHz to 2500 MHz with 1 kHz resolution
Input Signal Level	-100 dBm minimum
Measurement Bandwidth	8 kHz
Audio Output Bandwidth	4 kHz
Run Time	4 seconds per activation
<b>FM Demodulation</b>	Provides an audio output signal after FM demodulation of the user-selected signal to use for identifying a signal.
Measurement Frequency	30 MHz to 2500 MHz with 1 kHz resolution

**Table 4: Interference analysis characteristics (cont.)**

<b>Characteristic</b>	<b>Description</b>
Input Signal Level	-100 dBm minimum
Maximum Signal Deviation	Up to 100 kHz
Measurement Bandwidth	8 kHz, 15 kHz, 75 kHz, 200 kHz; selected by user
Audio Output Bandwidth	4 kHz for Measurement BW = 8 kHz, 15 kHz 15 kHz for Measurement BW = 75 kHz, 200 kHz
Run Time	4 seconds per activation
<b>Signal Strength Indicator</b>	Provides an audio tone and a visual display that vary with the strength of the selected signal.
Measurement Frequency	30 MHz to 2500 MHz with 1 kHz resolution
Input Signal Level	-110 dBm minimum

**Table 4: Interference analysis characteristics (cont.)**

Characteristic	Description
Measurement Bandwidth	Up to 10 MHz, dependent on span setting
Tone Type	Variable beep rate, based on signal strength Variable frequency tone, based on signal strength

**Table 5: Scanner characteristics**

Characteristic	Description
<b>W-CDMA Scrambling Code Analyzer</b>	Detects scrambling codes and pilot channel power levels of received co-channel W-CDMA downlink signals.
Input Signal Range	-117 to +30 dBm, typical
Units and Resolution	Io, Ec: dBm. Ec/Io: dB. 0.1 dB
Accuracy	Ec: ±2 dB for $E_c \geq -102$ dBm and $E_c/I_o \geq -12$ dB, typical ±3 dB for $E_c \geq -112$ dBm and $E_c/I_o \geq -14$ dB, typical
Display Controls	Sort by Power (descending Ec value) Sort by Scrambling Code (ascending SC index) Lock (set) current Scrambling Code set

**Table 5: Scanner characteristics (cont.)**

<b>Characteristic</b>	<b>Description</b>
<b>cdma2000 PN Scanner</b>	Detects PN Offset, Tau (Timing Error) and Pilot Channel power levels of multiple co-channel cdmaOne and/or cdma2000 forward link signals.
Input Signal Range	-120 to +30 dBm, typical
Units	Io, Ec: dBm Ec/Io: dB PN Offset: PN index (0 to 511) Tau: chips
Resolution	Ec, Io, Ec/Io: 0.1 dB PN Offset: 1 PN Tau: 0.1 chip
Accuracy	Ec: ±2 dB for $E_c \geq -95$ dBm and $E_c/I_o \geq -8$ dB, typical ±3 dB for $E_c \geq -110$ dBm and $E_c/I_o \geq -12$ dB, typical Tau: 0.5 chip, of highest power multipath component of each detected PNOS, relative to input timing reference (ESC or YBGPS1), typical.
Display Controls	Sort by Power (descending Ec value) Sort by PN offset (ascending offset values) Lock (set) current PN Offset values



Table 5: Scanner characteristics (cont.)

Characteristic	Description
<b>1xEV-DO PN Scanner</b>	<p>Detects PN Offset, Tau (Timing Error) and Pilot Channel power levels of multiple co-channel 1xEV-DO forward link signals. Up to 10 PN offsets are displayed.</p> <p>Io: The total received power in the pilot intervals of the signal, within the signal bandwidth (1.23 MHz).</p> <p>Ec: The absolute power level of the detected pilot at the indicated PN Offset, in dBm.</p>
Input Signal Range	-120 to +30 dBm, typical
Units	<p>Io, Ec: dBm</p> <p>Ec/Io: dB</p> <p>PN Offset: PN index (0 to 511)</p> <p>Tau: chips</p>
Resolution	<p>Ec, Io, Ec/Io: 0.1 dB</p> <p>PN Offset: 1 PN</p> <p>Tau: 0.1 chip</p>
Accuracy, typical	<p>Ec:</p> <p>± 2.5 dB for <math>E_c \geq -95</math> dBm and <math>E_c/I_o \geq -8</math> dB</p> <p>± 3.5 dB for <math>E_c \geq -110</math> dBm and <math>E_c/I_o \geq -12</math> dB</p> <p>Tau:</p> <p>±0.5 chip, of highest power multipath component of each detected PNOS, relative to input timing reference (ESC or YBGPS1)</p>

**Table 5: Scanner characteristics (cont.)**

<b>Characteristic</b>	<b>Description</b>
Display Controls	Sort by Power (descending Ec value) Sort by PN offset (ascending offset values) Lock (set) current PN Offset values
<b>GSM Channel Scanner</b>	The GSM channel scanner displays channel power and related information on a maximum of 128 GSM forward link signals. Displays Channel, Frequency, Peak Power, Traffic Type, C/I, and BSIC The scanner is intended for off-air reception using an antenna, and measures only forward (down) link signals. This measurement requires that YBT250 option GS1 is installed.
Input Signal Range	-120 to +30 dBm, typical
Units	Frequency: MHz Peak Power: dBm C/I: dB
Resolution	Frequency: 0.001 MHz Peak Power: 0.1 dBm C/I: 0.1 dB
Accuracy, typical	± 1 dB, -20 dBm to +30 dBm, ± 0.75 dB for identified GSM channels The center frequency is derived from the channel number. C/I is derived from EVM using the following equation: $C/I = -20 * \log_{10}(EVM/100)$

Table 5: Scanner characteristics (cont.)

Characteristic	Description
Display Controls	AutoLevel (graph) Sort table by power or frequency Start and stop channel select Peak hold
<b>TD-SCDMA Scanner</b>	Detects Sync code index, and DwPts Channel power levels of multiple co-channel TD-SCDMA forward link signals. Up to 10 Sync codes are displayed. Io: The total received power in the DwPts of the signal, within the signal bandwidth (1.6 MHz), in dBm. Ec: The absolute power level of the detected DwPts at the indicated Sync Code, in dBm.
Input Signal Range	-120 to +30 dBm, typical
Units	Io, Ec: dBm Ec/Io: dB Sync Code: Sync Code index (0 to 31)
Resolution	Ec, Io, Ec/Io: 0.1 dB Sync Code index: 1 code index offset

**Table 5: Scanner characteristics (cont.)**

Characteristic	Description
Accuracy, typical	Ec: $\pm 2.0$ dB for $E_c \geq -85$ dBm and $E_c/I_0 \geq -8$ dB $\pm 3.5$ dB for $E_c \geq -105$ dBm and $E_c/I_0 \geq -12$ dB
Display Controls	Sort by Power (descending $E_c$ value) Sort by Sync Code (ascending offset values) Lock (set) current Sync Code values

**Table 6: Signal Measurement characteristics**

Characteristic	Description
<b>RF Channel Power</b>	Measures the average RF power in a user-defined channel. The default value of channel bandwidth is taken from the selected standard. The acceptable values for channel numbers are taken from the selected standard. The user can input the channel center frequency instead of the channel number.
Units and Resolution	Watts (W), dBm 3 significant digits for W; 0.1 dB for dBm units
Accuracy	$\pm 0.75$ dB: $-20$ dBm to $+30$ dBm, $\pm 0.5$ dB typical $\pm 1.25$ dB: $-80$ dBm to $-20$ dBm, $\pm 1.0$ dB typical Reference information: Accuracy is guaranteed for input signals between $-80$ and $+30$ dBm total power (CW or peak envelope). Accuracy specification is typical down to $-120$ dBm total power.

**Table 6: Signal Measurement characteristics (cont.)**

<b>Characteristic</b>	<b>Description</b>
<b>RF Power (GSM/EDGE)</b>	Measures the average RF power of the useful part of a GSM or EDGE burst (GMSK or 8-PSK modulation), as determined by the location of the burst Training Sequence.
Units and Resolution	dBm: 0.01 dB for dBm units
Accuracy	For GSM or EDGE (GMSK or 8-PSK modulation) burst signals, the RF power measurement accuracy is: $\pm 1.0$ dB: -20 dBm to +30 dBm, $\pm 0.75$ dB typical $\pm 1.5$ dB: -80 dBm to -20 dBm, $\pm 1.25$ dB typical Reference information: Burst timing is determined from the location of the burst Training Sequence. If Burst timing cannot be found, the power measurement will be done on an arbitrarily selected segment of the signal equal to the useful part of a slot.
<b>RF Power (1xEV-DO)</b>	Measures the RF power in the Pilot, MAC, and Data intervals of a 1xEV-DO timeslot.
Units and Resolution	dBm: 0.01 dB for dBm units
Accuracy	For burst signals, the RF power measurement accuracy is: $\pm 1.0$ dB: -20 dBm to +30 dBm, $\pm 0.75$ dB typical $\pm 1.5$ dB: -80 dBm to -20 dBm, $\pm 1.25$ dB typical
<b>RF Power (TD-SCDMA)</b>	Measures the average RF power on individual timeslots (excluding the guard period) as determined by the location of the downlink pilot timeslot (DwPTS).
Units and Resolution	dBm: 0.01 dB for dBm units

**Table 6: Signal Measurement characteristics (cont.)**

<b>Characteristic</b>	<b>Description</b>
Accuracy	<p>For burst signals, the RF power measurement accuracy is:</p> <p><math>\pm 1.0</math> dB: <math>-20</math> dBm to <math>+30</math> dBm, <math>\pm 0.75</math> dB typical</p> <p><math>\pm 1.5</math> dB: <math>-80</math> dBm to <math>-20</math> dBm, <math>\pm 1.25</math> dB typical</p> <p>Reference information: Burst timing is determined from the power envelope profile of the DwPTS. If the DwPTS cannot be found, an error message is displayed.</p>
<b>RF Channel Carrier Frequency</b>	Measures the frequency of the carrier in the user selected channel. The user can enter a channel number or frequency.
Units and Resolution	MegaHertz (MHz): 1 Hz
Accuracy	<p><math>\pm (10 \text{ Hz} + \text{Time Base Error})</math>, 99% confidence interval</p> <p>W-CDMA: <math>\pm (12 \text{ Hz} + \text{Time Base Error})</math>, 99% confidence interval</p> <p>Note: The carrier frequency must be within 10 kHz of the expected value, except:</p> <p>W-CDMA, 1xEV-DO, and GSM/EDGE: within 5 kHz</p> <p>IS-136: within 1.5 kHz</p> <p>W-CDMA 3GPP Test Model 4</p>
Accuracy using YBGPS1 GPS Timing Reference	<p><math>\pm (10 \text{ Hz} + 0.015 \text{ ppm})</math>, typical</p> <p>Note: The carrier frequency must be within 10 kHz of the expected value, except:</p> <p>W-CDMA, 1xEV-DO, and GSM/EDGE: within 5 kHz</p> <p>IS-136: within 1.5 kHz</p> <p>The GPS antenna and the instrument antenna should be stationary for specified accuracy. Doppler shift of BST frequency is <math>\pm 0.09</math> ppm when the instrument antenna is moving at 60 mph (100 km/hr).</p>

Table 6: Signal Measurement characteristics (cont.)

Characteristic	Description
<b>FM Deviation</b>	Measures the maximum one-side frequency deviation of the analog FM cellular carrier selected by the user after demodulation. The user can enter a channel number or frequency.
Units and Resolution	kiloHertz (kHz): 0.1 kHz
Accuracy	± 10% for $2 \text{ kHz} \leq \text{Deviation} \leq 10 \text{ kHz}$ Maximum measurable deviation is 15 kHz peak. Maximum modulation frequency is 3 kHz.
<b>PN Offset</b>	Measures the PN Offset of the cdmaOne or cdma2000-1x signal. The user can select the CDMA signal of interest by a channel number or frequency.
Units and Resolution	PN Index: 1 PN Index, where each PN Index is 64 chips
Accuracy	Displayed PN Index must match the PN Offset of the CDMA signal.
<b>Pilot Time Alignment Error (Tau)</b>	Measures the time offset between the PN sequence of the input signal and the External Even Second Clock (on Timing Input connector).
Units and Resolution	Microsecond ( $\mu\text{s}$ ), Chips: 0.1 $\mu\text{s}$ (1 chip)
Accuracy	± 250 ns typical
<b>Waveform Quality (Rho, <math>\rho</math>)</b>	Measures the waveform quality as defined by IS-97-D using a pilot-only CDMA (or cdma2000-1x) signal.
Units and Resolution	None: 0.0001

**Table 6: Signal Measurement characteristics (cont.)**

<b>Characteristic</b>	<b>Description</b>
Accuracy	<p><math>\pm 0.005</math>, <math>0.9 \leq \rho \leq 1.0</math>; Usable range <math>0.5 \leq \rho \leq 1.0</math></p> <p>Degradation due to adjacent channel CDMA carriers (having equivalent power): add <math>\pm 0.015</math>.</p> <p>Reference information: The Rho measurement is only specified for a pilot-only CDMA signal. The accuracy specification given here applies only to measurements made on a pilot-only CDMA signal, with the instrument set to use the pilot-only method. For measurements on signals that are not pilot-only, see the Estimated Waveform Quality measurement.</p>
<b>Waveform Quality (Rho Pilot, Rho MAC, Rho Data) (1xEV-DO)</b>	<p>Rho (<math>\rho</math>) for 1xEV-DO signals provides an indication of the signal to distortion ratio for the transmitted signal. This quality measure is an indication of how similar the transmitted signal is to a perfect signal. Rho can vary between 0.0 and 1.0, where 1.0 represents a perfect signal.</p> <p>Rho Pilot is only computed on chips in the Pilot intervals. Pilot Rho is measured on the pilot interval of 20 half slots.</p> <p>Rho MAC is only computed on chips in the MAC interval. Rho MAC is measured on the MAC interval of 20 half slots.</p> <p>Rho Data is only computed on chips in the Data interval. Rho Data is measured on the Data interval of 20 half slots.</p>
Units and Resolution	None: 0.0001
Accuracy	<p><math>\pm 0.005</math>, <math>0.9 \leq \rho \leq 1.0</math>; Usable range <math>0.5 \leq \rho \leq 1.0</math></p> <p>Degradation due to adjacent channel CDMA carriers (having equivalent power): add <math>\pm 0.015</math>.</p>
<b>Estimated Waveform Quality</b>	Measures waveform quality as defined by IS-97-D using any CDMA signal.



Table 6: Signal Measurement characteristics (cont.)

Characteristic	Description
Units and Resolution	None: 0.0001
Accuracy	± 0.01 for rho ≥ 0.9, typical Reference information: The Rho measurement as given in IS-97-D is only specified for a pilot-only CDMA signal. This measurement makes an estimate of the Rho value on any CDMA signal.
<b>Error Vector Magnitude (EVM) (cdmaOne and cdma2000)</b>	The normalized RMS of all of the vectors that extend from the intended constellation points to the actual symbol points in a record of symbols.
Units and Resolution	Percent: 0.01%
Accuracy	±1%; EVM ≤ 31% Degradation due to adjacent channel CDMA carriers (having equivalent power): add 10% Residual error: 5% < 1000 MHz; 7% < 2000 MHz Reference information: These measurements are accurate for both pilot-only and in-service CDMA signals.
<b>Error Vector Magnitude (EVM) (W-CDMA)</b>	The normalized RMS of all of the vectors that extend from the intended constellation points to the actual symbol points in a record of symbols.
Units and Resolution	Percent: 0.01%

**Table 6: Signal Measurement characteristics (cont.)**

<b>Characteristic</b>	<b>Description</b>
Accuracy (W-CDMA composite)	<p><math>\pm 2.5\%</math>; <math>12.5\% \leq \text{EVM} \leq 22.5\%</math></p> <p>Residual error: 6% &lt; 1000 MHz; 8% &lt; 2500 MHz</p> <p>Reference information: The W-CDMA composite refers to a signal with one or more channels using QPSK modulation, or a combination of QPSK and 16QAM modulation. The EVM measurement readout displays the EVM for the composite signal. W-CDMA 3GPP Test Model 4.</p>
(W-CDMA EVM16QAM)	<p><math>\pm 1.5\%</math>; <math>6.5\% \leq \text{EVM}_{16\text{QAM}} \leq 22.5\%</math>, typical</p> <p>Residual error: 4%</p> <p>Reference information: The EVM16QAM measurement readout displays the symbol EVM for the code channels using 16QAM modulation.</p>
<b>Synchronization Channel Power (W-CDMA)</b>	Measures the Primary Synchronization Channel (P-SCH) and Secondary Synchronization Channel (S-SCH) power.
Units and Resolution	dBm, W: 0.1 dBm
<b>Carrier Feedthrough</b>	Measures the offset of the constellation from zero power.
Units and Resolution	dB relative to full carrier power: 0.1 dB
Accuracy	<p>cdmaOne and cdma2000: <math>\pm 2</math> dB</p> <p>Residual floor: <math>-50</math> dBc</p> <p>Reference information: For cdmaOne and cdma2000, the carrier feedthrough measurement is valid only for a pilot-only signal.</p>

**Table 6: Signal Measurement characteristics (cont.)**

<b>Characteristic</b>	<b>Description</b>
<b>Pilot Power</b>	Measures the absolute power of the pilot, without regard to whether other codes are present. (P-CPICH for W-CDMA.)
Units and Resolution	dBm, Watts (W): 0.1 dB
Accuracy	± 1 dB, -20 dBm to +30 dBm ± 1.5 dB, -50 dBm to -20 dBm Reference information: W-CDMA 3GPP Test Model 2.
<b>Sync Power</b>	Measures the absolute power of the W-CDMA sync channel (SCH), without regard to whether other codes are present.
Units and Resolution	dBm, Watts (W): 0.1 dB
<b>Occupied Bandwidth</b>	The Occupied Bandwidth measurement displays the frequency bandwidth within which 99% of the power transmitted on a single channel lies. This measurement can be properly made only if the channel being measured has no channels adjacent to it.
Units and Resolution	Hertz (Hz): Three significant digits
Accuracy	5% of the reading, typical Reference information: For TD-SCDMA signals, OBW is measured for each timeslot.
<b>Adjacent Channel Leakage power Ratio (ACLR) (W-CDMA)</b>	Measures the ratios of the mean RRC filtered power in the 5 MHz BW assigned channel to the mean RRC filtered power in each of the nearest 5 MHz BW 1st and 2nd adjacent upper and lower channels. Adjacent channel centers are offset in multiples of 5 MHz from the assigned channel center. The user can enter the channel center frequency instead of the channel number.

**Table 6: Signal Measurement characteristics (cont.)**

<b>Characteristic</b>	<b>Description</b>
Units and Resolution	dB: 0.01 dB
Accuracy	$\pm 1.5$ dB, $20 \leq \text{ACLR} < 48$ dB, typical $\pm 2.5$ dB, $48 \leq \text{ACLR} < 53$ dB, typical -30 dBm to +20 dBm (power in assigned channel) Reference information: WCDMA Test Model 1 signal (3G PP TS25.141). The filter response is Root-Raised Cosine (RRC), $\alpha = 0.22$ , and 3.84 MHz noise BW (3GPP TS25.104).
<b>Error Vector Magnitude (EVM) (GSM/EDGE)</b>	Error Vector Magnitude is the normalized RMS value of all of the vectors that extend from the intended constellation points to the actual symbol points in a record of symbols. The EVM measurement is made over one GSM or EDGE burst.
Units and Resolution	Percent: 0.01%
Accuracy	$\pm 1.5\%$ , $4\% \leq \text{EVM} < 10\%$ . Residual error: 4.0%
<b>Phase Error (GSM/EDGE)</b>	Phase Error is the RMS value of the differences between the phase angles of the received signal and those of an ideal reconstructed signal. The Phase Error measurement is made over one GSM or EDGE burst.
Units and Resolution	Degrees: 0.01°
Accuracy	$\pm 1.0$ , $2 \leq \text{Phase Error} < 12$ . Residual error: 2.0
<b>Origin Offset (GSM/EDGE)</b>	Origin Offset is the ratio of unmodulated signal power to modulated signal power. The unmodulated signal component causes the signal constellation center to be offset from the ideal location. The Origin Offset measurement is made over one GSM or EDGE burst.

Table 6: Signal Measurement characteristics (cont.)

Characteristic	Description
Units and Resolution	dB: 0.01 dB
Range	-15 dB to -60 dB
<b>Carrier to Interference (C/I) (GSM/EDGE)</b>	Carrier to Interference (C/I) is the ratio of desired signal (carrier) to undesired signal (interference). The C/I measurement is derived from the EVM result and gives an estimate of the power-based C/I value. The C/I measurement is made over one GSM or EDGE burst.
Units and Resolution	dB: 0.01 dB
Range	0 dB to 50 dB Reference information: C/I is derived from EVM using the following equation: $C/I = -20 * \log_{10}(EVM/100)$
<b>RF Power vs Time (GSM/EDGE)</b>	RF Power vs Time displays the normalized signal envelope power over one GSM or EDGE burst.
Units and Resolution	Symbols: 1 symbol. Microseconds: 1 microsecond.
Time Uncertainty	$\pm 0.2$ symbol $\pm 0.8$ microsecond Reference information: Burst to mask alignment is derived from the location of the Training Sequence in the useful part of the burst.

**Table 7: Environmental characteristics**

<b>Characteristic</b>	<b>Description</b>
Temperature Range	Operating: 0 °C to +50 °C specified performance, -10 °C to +50 °C typical Nonoperating: -40 °C to +60 °C
Humidity	Operating: 5% to 95% Relative Humidity (RH), noncondensing: up to +30 °C Nonoperating: 5% to 45% Relative Humidity (RH), noncondensing: +30 °C up to +50 °C
Altitude	Operating: Up to 4,600 m (15,092 ft.) Nonoperating: Up to 15,240 m (50,000 ft.)

**Table 8: Physical characteristics**

<b>Characteristic</b>	<b>Description</b>
Dimensions	Height: 25 cm. (9.75 in) Width: 33 cm. (13 in) Depth: 9 cm. (3.5 in)
Weight	5.5 kg (12.125 lbs): Y400, YBT250, and 1 battery

**Table 9: Miscellaneous characteristics**

<b>Characteristic</b>	<b>Description</b>
Battery Life	One battery installed: 2 hours with measurements active, 4 hours in suspend mode Two batteries installed: 4 hours with measurements active, 8 hours in suspend mode
Recommended Instrument Calibration Interval	2 years

**Table 10: Safety compliance**

<b>Category</b>	<b>Description</b>
Safety Compliance	ANSI/UL61010-1:2004 Electrical Equipment for Measurement, Control, and Laboratory Use. CSA C22.2 No. 61010.1:2004 Electrical Equipment for Measurement, Control, and Laboratory Use. EN 61010-1:2001 Electrical Equipment for Measurement, Control, and Laboratory Use. IEC61010-1:2001 Electrical Equipment for Measurement, Control, and Laboratory Use. ISA 82.02.01 Electrical Equipment for Measurement, Control, and Laboratory Use.

## Certifications and Compliances

### EC Declaration of Conformity – EMC

Meets intent of Directive 2004/108/EEC for Electromagnetic Compatibility. Compliance was demonstrated to the following specifications as listed in the Official Journal of the European Communities:

**EN 61326:1997.** EMC requirements for Class A electrical equipment for measurement, control, and laboratory use. <sup>1, 2, 3, 4</sup>

- IEC 61000-4-2:1999. Electrostatic discharge immunity (Performance criterion C)
- IEC 61000-4-3:2002. RF electromagnetic field immunity (Performance criterion A) <sup>5</sup>
- IEC 61000-4-4:2004. Electrical fast transient / burst immunity (Performance criterion B)
- IEC 61000-4-5:2005. Power line surge immunity (Performance criterion B)
- IEC 61000-4-6:2003. Conducted RF immunity (Performance criterion A) <sup>5</sup>
- IEC 61000-4-11:2004. Voltage dips and interruptions immunity (Performance criterion B)

**EN 61000-3-2:2000.** AC power line harmonic emissions

**EN 61000-3-3:1995.** Voltage changes, fluctuations, and flicker

#### European Contact.

Tektronix UK, Ltd.  
Western Peninsula  
Western Road  
Bracknell, RG12 1RF  
United Kingdom



- 1 This product is intended for use in nonresidential areas only. Use in residential areas may cause electromagnetic interference.
- 2 Emissions which exceed the levels required by this standard may occur when this equipment is connected to a test object.
- 3 To ensure compliance with the EMC standards listed here, high quality shielded interface cables should be used.
- 4 Minimum Immunity test requirement.
- 5 Performance Criteria: Residual spurious signals can increase to  $-70$  dBm with exposure to the disturbance levels of this test.

### **Australia / New Zealand Declaration of Conformity – EMC**

Complies with the EMC provision of the Radiocommunications Act per the following standard, in accordance with ACMA:

- EN 61326:1997. EMC requirements for electrical equipment for measurement, control, and laboratory use.



# Index

## Symbols and Numbers

?, 25

## A

AC adapter, connecting, 4  
 Accessories, standard, 1  
 Adapter, AC, connecting, 4  
 Add a marker to a waveform, 37  
 Add signal standards to select list, 12  
 Altitude specifications, 2  
 Amplifier, RF input signal, 22  
 Attenuator, RF input signal, 22  
 Audio tab, 49

## B

Battery  
     charge status, 16  
     charge times, 5  
     charging, 5  
 Button  
     channel select, 21  
     downlink, 21, 27  
     Edit, 20

F EXT, 22  
 F GPS, 22  
 F INT, 22  
 forward link, 21  
 frequency select, 21  
 GPS status, 22  
 help, 25  
 Help, 20  
 measurement mode, 23  
 measurement reference  
     frequency status, 22  
 measurement sequencer  
     mode, 23  
 Open, 20  
 Pause, 20  
 power on/standby, 16  
 reset, 16  
 reverse link, 21  
 RF input signal gain/loss, 22  
 Run, 20  
 save results, 20  
 signal measurement mode, 23  
 spectrum measurement  
     mode, 23

traces, 38  
 uplink, 21, 27

## C

Calibrate the touch screen, 8  
 Changing  
     application screen colors for  
       printing, 11  
     numbers in fields, 24  
     spectrum frequency span, 34  
     spectrum graph reference  
       level, 35  
     spectrum graph vertical scale, 35  
 Channel scanner measurements  
     (interference), 54  
 Channel select button, 21  
 Charging the batteries, 5  
 Cleaning the instrument, 3  
 Clock, Even Second, 18  
 Command bar, 19, 20  
 Comparing waveforms (spectrum)  
     live and saved waveforms, 41  
     two live waveforms, 38  
     two saved waveforms, 43

Concepts, touch screen, 7  
Connecting the AC adapter, 4  
Connectors  
    input & output (Y400), 17  
    Reference Frequency Input, 18  
    RF Input, 18  
    Timing Input, 18  
    YBT250 module, 18  
Conventions used in this manual, ix

## D

Dimensions, 2  
Displaying  
    a Spectrogram, 44  
    a spectrum waveform, 34  
    channel scanner measurements, 54  
    markers, 36  
    power on/off status, 16  
    scrambling code measurements, 54  
Documentation, viii  
Downlink button, 21, 27  
Drag, 7

## E

Edit button, 20  
EMF measurement, 52  
EMF tab, 52  
Enabling signal standards, 12  
Entering numbers in fields, 24  
ESC, 18  
Ethernet connector (RJ-45), 17  
Even Second Clock, 18  
External Reference status button, 19  
External RF input signal amplifier, 22  
External RF input signal attenuator, 22  
External timing reference signal input, 18

## F

Forward link button, 21  
Frequency reference input specification, YBT250, 62  
Frequency select button, 21  
Frequency span (spectrum), 34  
Functional verification, 6

## G

Getting help on measurements, 25

GPS status button, 19, 22

## H

Headphone jack, 17  
Help  
    accessing online help, 25  
    button, 20  
    link text, 25  
Humidity operation specifications, 2

## I

Identify tab, 46  
Identifying an interfering signal, 46  
Improve measurement accuracy, 18  
Indoor color scheme, 11  
Input field entry controls, 24  
Input signal characteristics, 2  
Input/Output connectors, 17  
Installation, 1  
Instrument cleaning, 3  
Instrument elements, 15  
Interference measurements  
    Audio, 49  
    EMF, 52  
    Identify, 46  
    measurement tabs, 45

Noise, 51  
Scan, 54  
Strength, 48

Interfering signal audio  
demodulation, 49

## K

Key features, vii  
Keypad button, 24  
Knob control, 24

## L

Lightning, preventing personal  
injury, x  
Listening to an interfering signal, 49  
Live and saved waveforms,  
comparing, 41  
Loading sequencer measurement  
settings, 59  
Locating an interfering signal, 48

## M

Markers  
add a marker to a waveform, 37  
displaying, 36

moving a marker, 37  
overview, 36  
turning on or off, 36

### Measurement

mode buttons, 19, 23  
reference frequency status  
button, 22  
results screen, 19

### Measurement sequencer

loading saved measurement  
sequences, 59  
mode button, 23  
saving measurement  
sequences, 59

Measurements between waveforms  
(Spectrum), 40

Measuring EMF (interference), 52

Measuring noise floor  
(interference), 51

Menus, 20

Microphone input, 17

Microsoft WindowsCE user  
interface, 18

Moving a marker on a waveform, 37

Multiple measurements, 58

## N

Noise floor measurement, 51  
Noise tab, 51

## O

Online help, 25  
Open button, 20  
Opening YBT250, 10  
Operating considerations, 2  
Outdoor color scheme, 11

## P

Parameter entry controls, 19, 24  
Parts of the instrument, 15  
Pause button, 20  
Power On/Standby button, 16  
Power/Display status, 16  
Powering on and off the instrument, 6  
Preventing personal injury from  
lightning, x  
PS/2 keyboard connector, 17

## R

Ref Lvl scale (spectrum), 35  
Reset button, 16

Reverse link button, 21  
RF input

- characteristics, 2
- signal connector, 18
- signal gain/loss button, 22
- YBT250, 61

RF Signal Gain/Loss status button, 19  
Run button, 20  
Running YBT250, 10

## S

Safety Summary, iii  
Save results button, 20  
Saved waveforms, comparing (spectrum), 43  
Saving sequencer measurement settings, 59  
Scan tab, 54  
Scrambling code measurements (interference), 54  
Screen display colors, 11  
Selecting signal standard to measure, 21  
Selecting waveforms (traces), 38  
Serial RS-232 connector, 17  
Setting

- display colors, 11
- signal standards, 12
- the channel number, 21
- the measurement frequency, 21
- to take a measurement, 27

Setup dialog box, 34  
Signal audio demodulation, 49  
Signal identification (interference), 46  
Signal input characteristics, 2  
Signal input connectors

- Reference Frequency Input, 18
- RF Input, 18
- Timing Input, 18

Signal locating (interference), 48  
Signal measurement mode button, 23  
Signal standard selection list, 21  
Software upgrades, ix  
Span, 34  
Specifications, 61  
Spectrogram, displaying, 44  
Spectrum

- add a marker to a waveform, 37
- change frequency span, 34
- change graph reference level, 35
- change graph vertical scale, 35
- comparing live and saved waveforms, 41

- comparing two live waveforms, 38
- comparing two saved waveforms, 43
- display a spectrogram, 44
- displaying a waveform, 34
- displaying markers, 36
- markers overview, 36
- saved waveforms, comparing, 43
- selecting waveforms (traces), 38
- traces button, 38
- turning on or off markers, 36
- using markers on different waveforms, 40
- waveforms (traces), selecting, 38

Spectrum measurement mode button, 23  
Standard accessories, 1  
Starting YBT250, 10  
Status panel, 16  
Strength tab, 48  
Stylus, 7

## T

Tab

- Audio (Interference mode), 49

- EMF (Interference mode), 52
- Identify (Interference mode), 46
- Noise (Interference mode), 51
- Scan (Interference mode), 54
- Strength (Interference mode), 48
- Taking a channel measurement, 32
- Taking a spectrum measurement, 34
- Tap, 7
- Temperature range operation
  - specifications, 2
- Timing input specification, YBT250, 63
- Touch screen
  - calibrate, 8
  - concepts, 7
  - on/off status, 16
- Trace 1, Trace 2, 38
- Traces button, 38
- Tuning controls, 19, 21
- Turning on or off markers, 36

## U

- Underlined blue text, 25
- Unpack the instrument, 1
- Updates button (spectrogram), 44
- Upgrades, software, ix

- Uplink button, 21, 27
- USB Host connector, 17
- USB Slave connector, 17
- User interface
  - command bar, 19, 20
  - External Reference status button, 19
  - GPS status button, 19
  - Measurement mode buttons, 19
  - measurement results screen, 19
  - menus, 20
  - overview, 19
  - Parameter entry controls, 19
  - RF Signal Gain/Loss status button, 19
  - tuning controls, 19

## V

- Verifying instrument functionality, 6
- Vertical Scale (spectrum), 35

## W

- Waveforms (spectrum)
  - add a measurement marker, 37

- change graph reference level, 35
- change graph vertical scale, 35
- comparing, 38
- comparing live and saved waveforms, 41
- comparing two live waveforms, 38
- comparing two saved waveforms, 43
- moving a marker on a waveform, 37
- selecting traces, 38
- Weight, 2

## Y

- Y400 user interface elements, 18
- YBT250 module connectors
  - FREQUENCY REFERENCE input specification, 62
  - Reference Frequency Input, 18
  - RF Input, 18
  - RF input specification, 61
  - Timing Input, 18
  - TIMING input specification, 63